

7.3W DUAL AUDIO POWER IC

The KIA6248K is dual audio power amplifier for application.

It contains various kind of protectors and the function of stand-by switch.

FEATURES

- Output Power
 - : $P_{OUT(1)}$ = 7.3W (Typ.)
(V_{CC} = 13.2V, R_L = 2 Ω , f = 1kHz, THD = 10%)
 - : $P_{OUT(2)}$ = 6.4W (Typ.)
(V_{CC} = 14.4V, R_L = 4 Ω , f = 1kHz, THD = 10%)
 - : $P_{OUT(3)}$ = 5.3W (Typ.)
(V_{CC} = 13.2V, R_L = 4 Ω , f = 1kHz, THD = 10%)
- Total Harmonic Distortion
 - : THD = 0.1% (Typ.)
(V_{CC} = 13.2V, R_L = 4 Ω , f = 1kHz, P_{OUT} = 1W)
- Built-in Stand-by Switch Function
 - : I_{STBY} = 1 μ A (Typ.)
(With ⑨ pin set at High, power is turned ON.)
- Built-in Various Protection Circuits
 - : OVER Voltage, Thermal Shut Down
Out to GND, out to V_{CC} Short
- Built-in Junction Temperature Detection Function
(Pin ① : 10mW/ $^{\circ}$ C)
- Operation supply voltage range : V_{CC} = 6~18V.

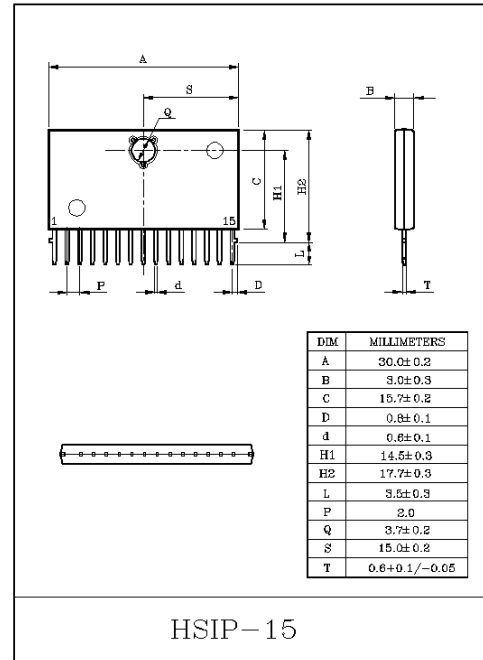

KIA6248K

MAXIMUM RATINGS (Ta=25°C)

CHARACTERISTIC	SYMBOL	RATING	UNIT
Peak Supply Voltage (0.2 sec)	V _{CC surge}	50	V
DC Supply Voltage	V _{CC DC}	20	V
Operating Supply Voltage	V _{CC opr}	18	V
Output Current (Peak)	I _{O(peak)}	4.5	A
Power Dissipation	P _D	15	W
Operating Temperature	T _{opr}	-30~85	°C
Storage Temperature	T _{stg}	-55~150	°C

ELECTRICAL CHARACTERISTICS

(Unless otherwise specified, V_{CC}=13.2V, f=1kHz, R_g=600Ω, R_L=4Ω, Ta=25°C)

CHARACTERISTIC	SYMBOL	TEST CONDITION	MIN.	TYP.	MAX.	UNIT
Quiescent Current	I _{CCQ}	V _{IN} =0	-	60	150	mA
Output Power	P _{OUT} (1)	R _L =2Ω, THD=10%	-	7.3	-	W
	P _{OUT} (2)	V _{CC} =14.4V, THD=10%	-	6.4	-	
	P _{OUT} (3)	THD=10%	4.8	5.3	-	
Total Harmonic Distortion	THD	P _{OUT} =1W	-	0.1	0.5	%
Voltage Gain	G _V	V _{OUT} =0dBm	50	52	54	dB
Voltage Gain Ratio	Δ G _V	V _{OUT} =0dBm	-1	0	1	dB
Output Noise voltage	V _{NO}	R _g =0Ω, BW=20Hz~20kHz	-	0.20	0.7	mV _{rms}
Ripple Rejection Ratio	R.R	R _g =600Ω, V _{RIP} =0dBm, f _{RIP} =100Hz	40	57	-	dB
Cross Talk	C.T	R _g =600Ω, V _{OUT} =0dBm	-	65	-	dB
Input Resistance	R _{IN}	-	-	30	-	kΩ
Stand-By Current	I _{STBY}	Pin ⑨ : GND	-	1	10	μA

KIA6248K

BLOCK DIAGRAM / TEST CIRCUIT

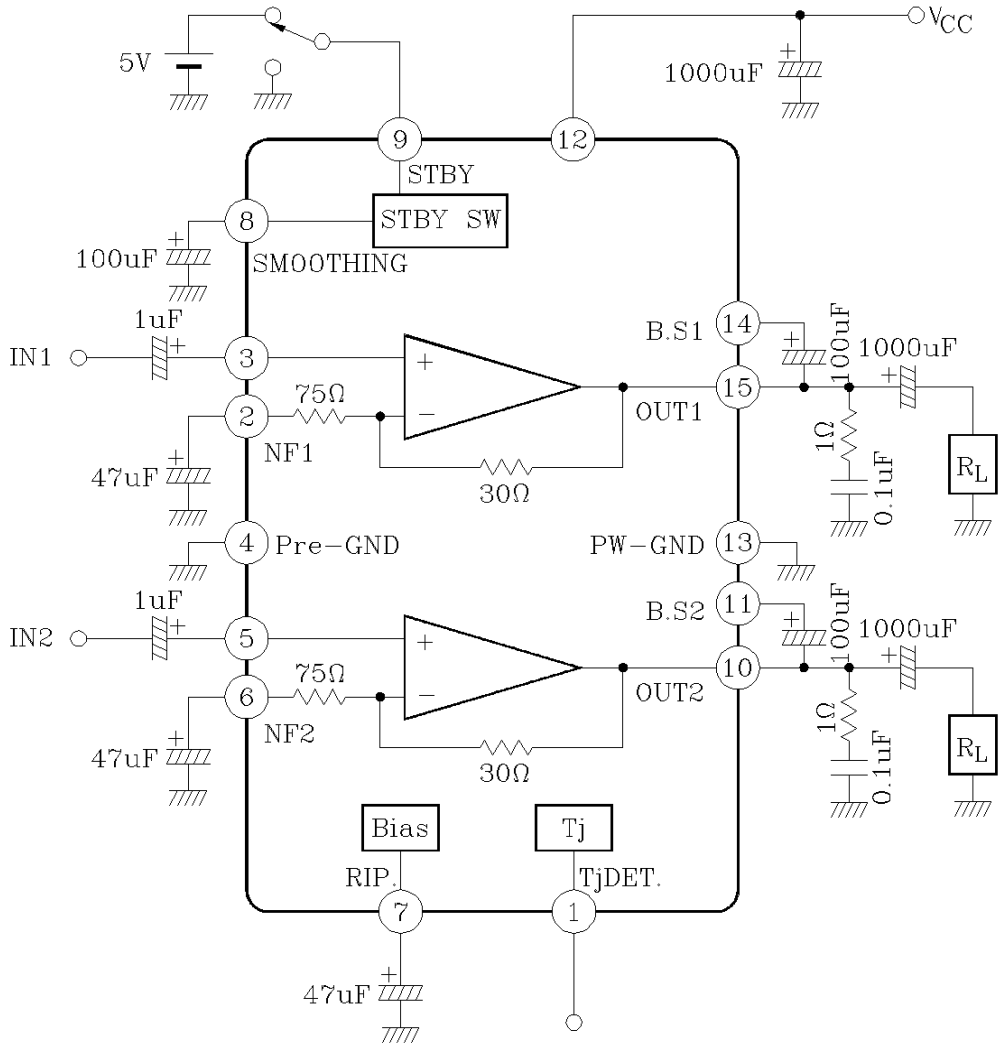

KIA6248K

APPLICATION CIRCUIT (BTL MODE)

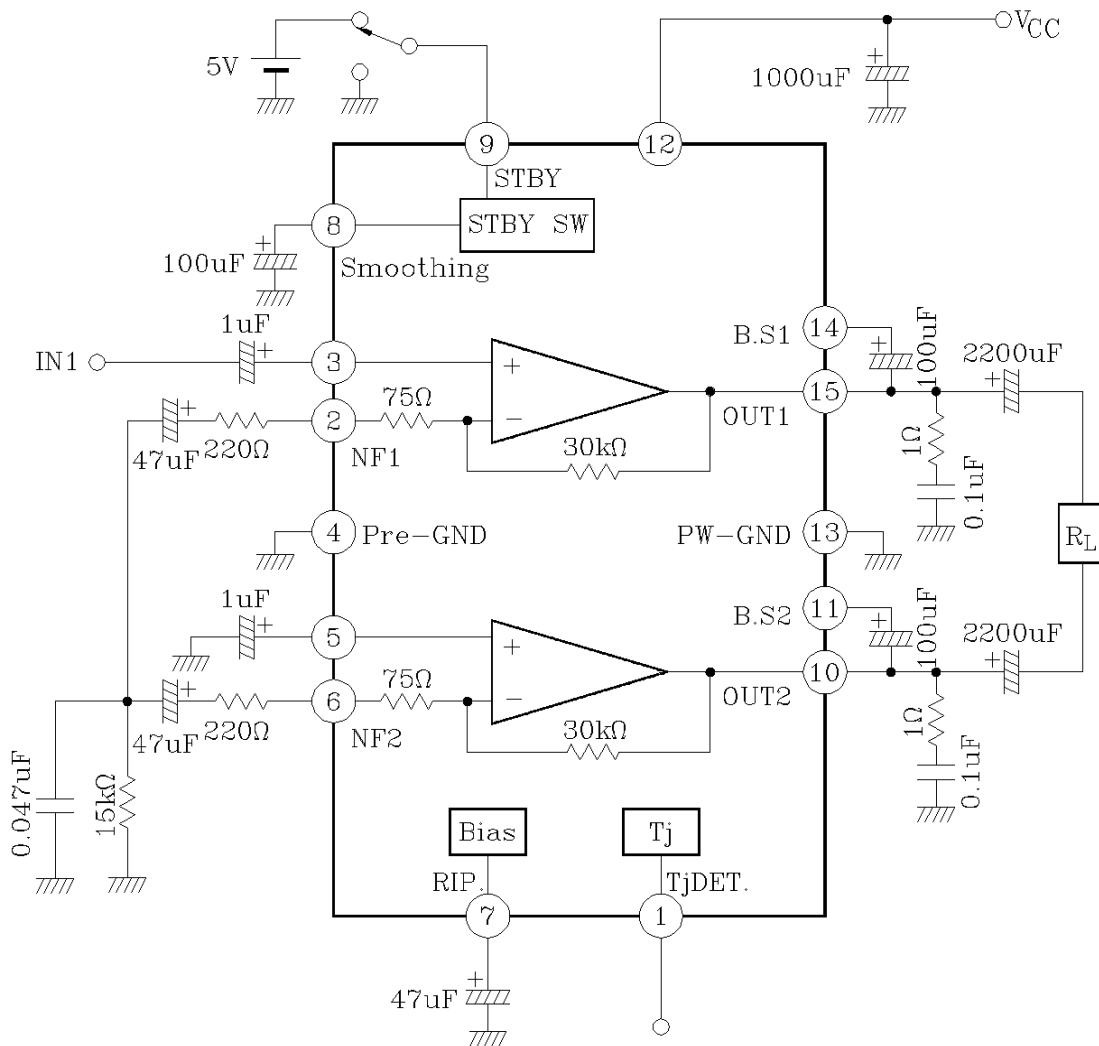

KIA6248K

CAUTION AND APPLICATION METHOD (Description is made only on the single channel.)

1. Voltage Gain Adjustment

The closed loop voltage gain (G_V) is determined by R_1 , R_2 and R_f .

$$G_V = 20 \log \frac{R_f + R_1 + R_2}{R_f + R_1} \text{ (dB)}$$

When $R_f=0$, $G_V=52\text{dB(Typ.)}$ is given.

The voltage gain is reduced when R_f is increased.
(Fig.2)

With the voltage gain reduced, since the oscillation stability is reduced, refer to the items 3.

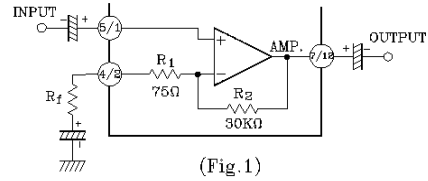

(Fig.1)

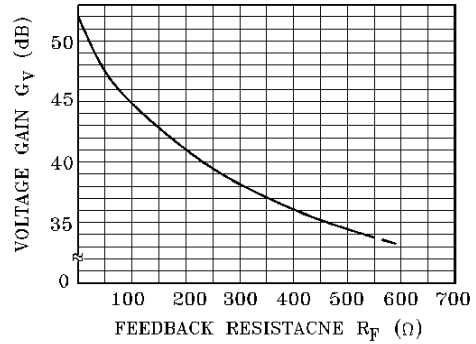

(Fig.2)

2. Stand-by SW Function

By means of controlling pin⑨ (Stand-by terminal) to high and low, the power supply can be set to ON and OFF. The threshold voltage of pin⑨ is set at $2.1V(3V_{BE})$, and the power supply current is about $1\mu A$ (Typ.) at the stand-by state.

Control Voltage pin⑨ : $V(SB)$

Stand-by	Power	$V(SB)$ (V)
ON	OFF	0~2
OFF	ON	3~ V_{CC}

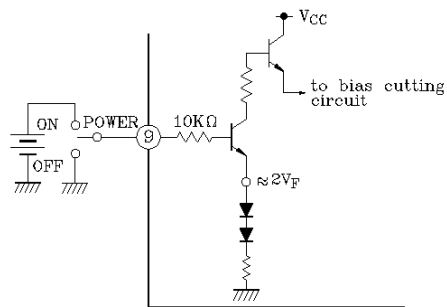

(Fig.3) With pin ⑨ set to High, Power is turned ON

Advantage of Stand-by SW

- (1) Since V_{CC} can directly be controlled to ON, OFF by the microcomputer, the switching relay can be omitted.
- (2) Since the control current is microscopic, the switching relay of small current capacity is satisfactory for switching.

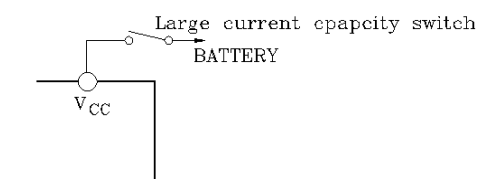

- Conventional Method -

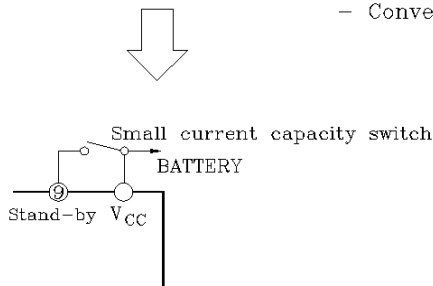
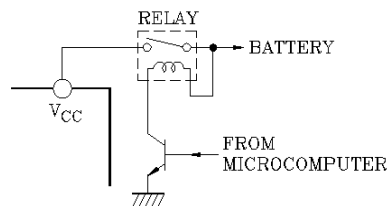

- Stand-by Switch Method -

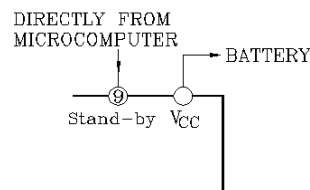

KIA6248K

3. Preventive Measure Against Oscillation

C_{OSC} : For preventing the oscillation, it is advisable to use C_{OSC} , the condenser of polyester film having small characteristic fluctuation of the temperature and the frequency.

The resistance R to be series applied to C_{OSC} is effective for phase correction of high frequency, and improves the oscillation allowance.

- (1) Voltage gain to be used (G_V Setting)
- (2) Capacity value of condenser
- (3) Kind of condenser
- (4) Layout of printed board

In case of its use with the voltage gain G_V reduced or with the feedback amount increased, care must be taken because the phase-inversion is caused by the high frequency resulting in making the oscillation liable generated.

4. Junction Temperature Detecting pin ①

Using temperature characteristic of a band gap circuit and in proportion to junction temperature, pin① DC voltage : V_1 rises at about $+10\text{mV}/^\circ\text{C}$ temperature characteristic. So, the relation between V_1 at $T_j=25^\circ\text{C}$ and V_{1x} at $T_j=x^\circ\text{C}$ is decided by the following expression :

$$T(x^\circ\text{C}) = \frac{V_{1x} - V_1(25^\circ\text{C})}{10\text{mV}/^\circ\text{C}} + 25(^\circ\text{C})$$

In deciding a heat sink size, a junction temperature can be easily made clear by measuring voltage at this pin while a backside temperature of IC was so far measured using a thermocouple type thermometer.

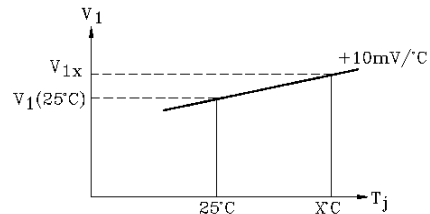

(Fig.4)

5. Pop Noise

The pop noise is reduced by the time constant τ of pin⑧ : smoothing.

Therefore, we recommend $C_S=100\mu\text{F}$, which is between pin⑧ and GND, because the pop noise will become worse by using the smaller capacity of C_S .

$C_S=100\mu\text{F}$: RECOMMENDED VALUE

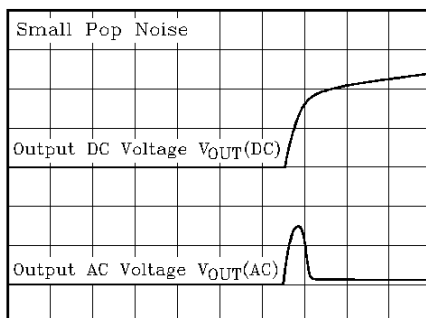

OUTPUT DC VOLTAGE 2V/DIV, 20ms/DIV
OUTPUT AC VOLTAGE 1V/DIV, 20ms/DIV

$C_S=10\mu\text{F}$: LESS THAN RECOMMENDED VALUE

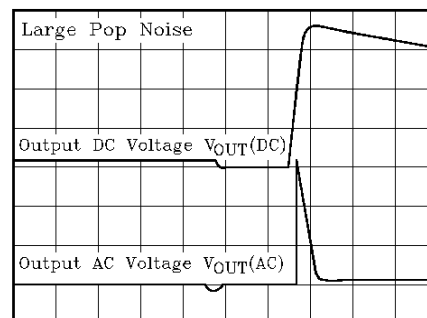

OUTPUT DC VOLTAGE 2V/DIV, 20ms/DIV
OUTPUT AC VOLTAGE 1V/DIV, 20ms/DIV

KIA6248K

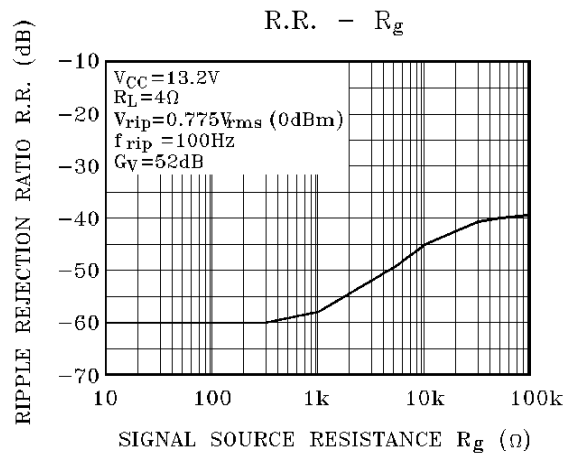
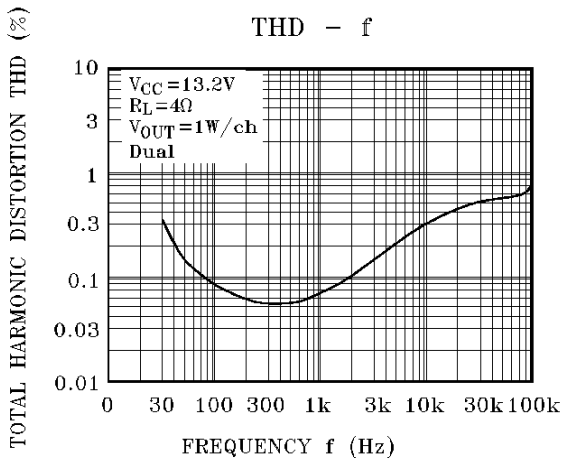
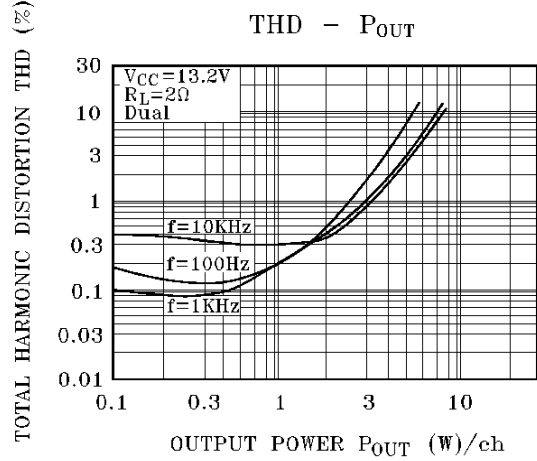
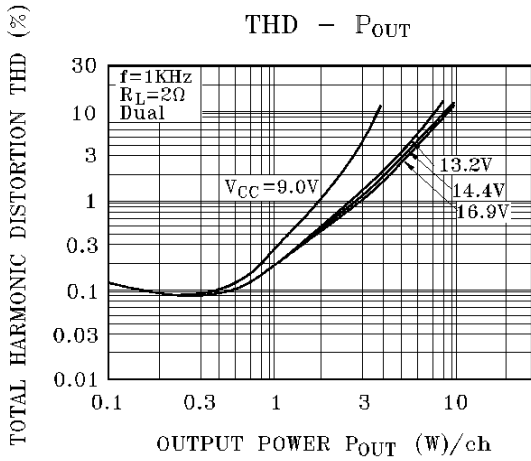
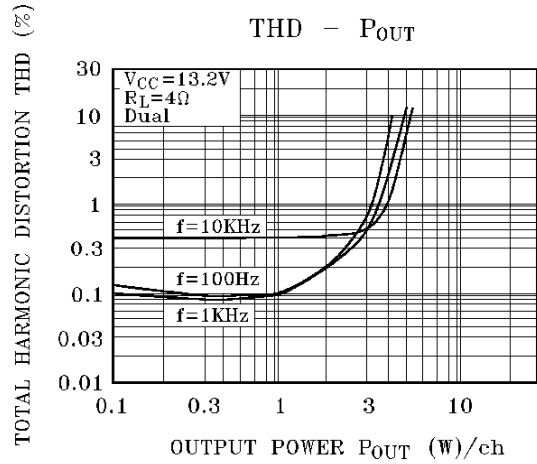
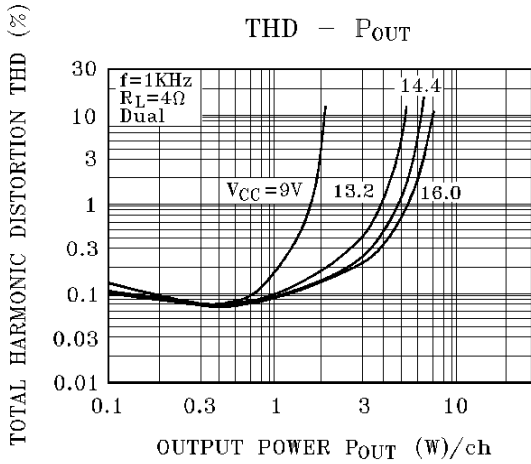

KIA6248K

