

# DATA SHEET

**TDA1564J**

**Run-cool stereo power amplifier**

Preliminary specification  
File under Integrated Circuits, IC01

2002 Jan 14

## Run-cool stereo power amplifier

## TDA1564J

## FEATURES

- Low dissipation due to switching from Single-Ended (SE) to Bridge-Tied Load (BTL) mode
- Differential inputs with high Common Mode Rejection Ratio (CMRR)
- Mute/standby/operating (mode select pin)
- Load dump protection circuit
- Short-circuit safe to ground, to supply voltage and across load
- Loudspeaker protection circuit
- Offset detection for each channel
- Device switches to single-ended operation at excessive junction temperatures
- Thermal protection at high junction temperature (170°C)
- Clip detection at THD = 2.5%
- Diagnostic information (clip/protection/prewarning/offset).

## GENERAL DESCRIPTION

The TDA1564J is a monolithic power amplifier in a 17-lead single-in-line (SIL) plastic power package. It contains two identical 25 W amplifiers. The dissipation is minimized by switching from SE to BTL mode, only when a higher output voltage swing is needed. The device is primarily developed for car radio applications.

## QUICK REFERENCE DATA

SYMBOL	PARAMETER	CONDITIONS	MIN.	TYP.	MAX.	UNIT
$V_P$	supply voltage	DC biased	6.0	14.4	18	V
		non-operating	–	–	30	V
		load dump	–	–	45	V
$I_{ORM}$	repetitive peak output current		–	–	4	A
$I_{q(tot)}$	total quiescent current	$R_L = \infty$	–	95	150	mA
$I_{stb}$	standby current		–	1	50	$\mu$ A
$ Z_i $	input impedance		90	120	150	k $\Omega$
$P_o$	output power	$R_L = 4 \Omega$ ; EIAJ	–	38	–	W
		$R_L = 4 \Omega$ ; THD = 10%	23	25	–	W
		$R_L = 4 \Omega$ ; THD = 2.5%	18	20	–	W
$G_v$	voltage gain		25	26	27	dB
CMRR	common mode rejection ratio	$f = 1 \text{ kHz}$ ; $R_s = 0 \Omega$	–	80	–	dB
SVRR	supply voltage ripple rejection	$f = 1 \text{ kHz}$ ; $R_s = 0 \Omega$	45	65	–	dB
$ \Delta V_O $	DC output offset voltage		–	–	100	mV
$\alpha_{cs}$	channel separation	$R_s = 0 \Omega$	40	70	–	dB
$ \Delta G_v $	channel unbalance		–	–	1	dB

## ORDERING INFORMATION

TYPE NUMBER	PACKAGE		
	NAME	DESCRIPTION	VERSION
TDA1564J	DBS17P	plastic DIL-bent-SIL power package; 17 leads (lead length 12 mm)	SOT243-1

Run-cool stereo power amplifier

TDA1564J

BLOCK DIAGRAM

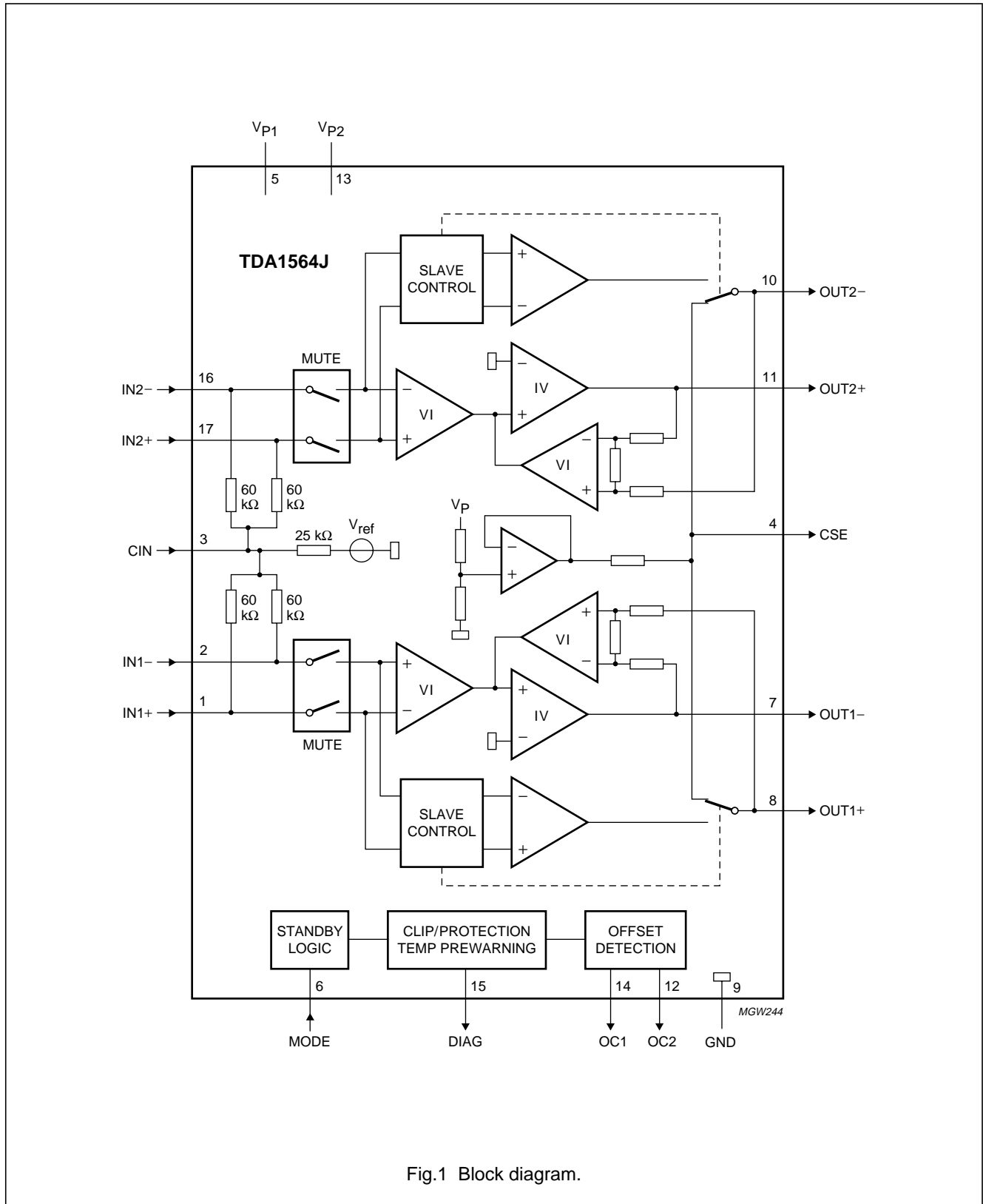

Fig.1 Block diagram.

Run-cool stereo power amplifier

TDA1564J

**PINNING**

SYMBOL	PIN	DESCRIPTION
IN1+	1	non-inverting input 1
IN1-	2	inverting input 1
CIN	3	common input
CSE	4	electrolytic capacitor for single-ended (SE) mode
V <sub>P1</sub>	5	supply voltage 1
MODE	6	mute/standby/operating
OUT1-	7	inverting output 1
OUT1+	8	non-inverting output 1
GND	9	ground
OUT2-	10	inverting output 2
OUT2+	11	non-inverting output 2
OC2	12	offset capacitor 2
V <sub>P2</sub>	13	supply voltage 2
OC1	14	offset capacitor 1
DIAG	15	diagnostic
IN2-	16	inverting input 2
IN2+	17	non-inverting input 2

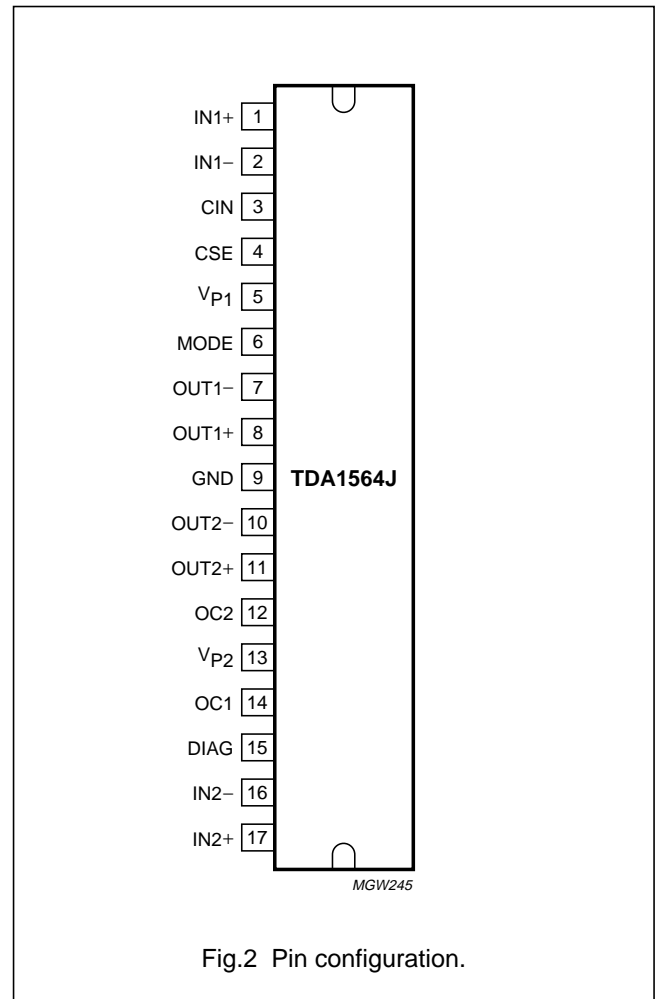

Fig.2 Pin configuration.

## Run-cool stereo power amplifier

## TDA1564J

**FUNCTIONAL DESCRIPTION**

The TDA1564J contains two identical amplifiers with differential inputs. At low output power [up to output amplitudes of 3 V (RMS) at  $V_P = 14.4$  V], the device operates as a normal SE amplifier. When a larger output voltage swing is needed, the circuit switches internally to BTL operation.

With a sine wave input signal, the dissipation of a conventional BTL amplifier (up to 2 W output power) is more than twice the dissipation of the TDA1564J; see Fig.10.

In normal use, when the amplifier is driven with music-like signals, the high (BTL) output power is only needed for a small percentage of time. Assuming that a music signal has a normal (Gaussian) amplitude distribution, the dissipation of a conventional BTL amplifier with the same output power is approximately 70% higher (see Fig.11).

The heatsink has to be designed for use with music signals. With such a heatsink, the thermal protection will disable the BTL mode when the junction temperature exceeds 150 °C. In this case, the output power is limited to 5 W per amplifier.

The gain of each amplifier is internally fixed at 26 dB. The device can be switched to the following modes via the MODE pin:

- Standby with low standby current (<50  $\mu$ A)
- Mute condition, DC adjusted
- On, operation.

The device is fully protected against a short-circuit of the output pins to ground and to the supply voltage. It is also protected against a short-circuit of the loudspeaker and against high junction temperatures. In the event of a permanent short-circuit condition to ground or the supply voltage, the output stage will be switched off, causing low dissipation. With a permanent short-circuit of the loudspeaker, the output stage will be repeatedly switched on and off. The duty cycle in the 'on' condition is low enough to prevent excessive dissipation.

The device also has two independent DC offset detection circuits that can detect DC output voltages across the speakers. With a DC offset greater than 2 V, a warning is given on the diagnostic pin. There will be no internal shutdown with DC offsets.

When the supply voltage drops below 6 V (e.g. engine start), the circuit mutes immediately, avoiding clicks from the electronic circuit preceding the power amplifier.

The voltage of the SE electrolytic capacitor (pin 4) is kept at  $0.5V_P$  by means of a voltage buffer (see Fig.1). The value of this capacitor has an important influence on the output power in SE mode, especially at low signal frequencies. A high value is recommended to minimize dissipation at low frequencies.

The diagnostic output is an open-collector output and requires a pull-up resistor. It gives the following outputs:

- Clip detection at THD = 2.5%
- Short-circuit protection:
  - When a short-circuit occurs (for at least 10  $\mu$ s) at the outputs to ground or the supply voltage, the output stages are switched off to prevent excessive dissipation; the outputs are switched on again approximately 500 ms after the short-circuit is removed, during this short-circuit condition the protection pin is LOW
  - When a short-circuit occurs across the load (for at least 10  $\mu$ s), the output stages are switched off for approximately 500 ms; after this time, a check is made to see whether the short-circuit is still present
  - The power dissipation in any short-circuit condition is very low.
- During start-up/shutdown, when the product is internally muted
- Temperature prewarning:
  - A prewarning (junction temperature > 145 °C) indicates that the temperature protection will become active. The prewarning can be used to reduce the input signal and thus reduce the power dissipation
- Offset detection:
  - One of the channels has a DC output voltage greater than 2 V.

# Run-cool stereo power amplifier

# TDA1564J

## LIMITING VALUES

In accordance with the Absolute Maximum Rating System (IEC 60134).

SYMBOL	PARAMETER	CONDITIONS	MIN.	MAX.	UNIT
V <sub>P</sub>	supply voltage	operating	–	18	V
		non-operating	–	30	V
		load dump; t <sub>r</sub> > 2.5 ms	–	45	V
V <sub>P(sc)</sub>	short-circuit safe voltage		–	18	V
V <sub>rp</sub>	reverse polarity voltage		–	6	V
I <sub>ORM</sub>	repetitive peak output current		–	4	A
P <sub>tot</sub>	total power dissipation		–	60	W
T <sub>stg</sub>	storage temperature		–55	+150	°C
T <sub>vj</sub>	virtual junction temperature		–	150	°C
T <sub>amb</sub>	ambient temperature		–40	–	°C

## THERMAL CHARACTERISTICS

SYMBOL	PARAMETER	CONDITIONS	VALUE	UNIT
R <sub>th(j-c)</sub>	thermal resistance from junction to case	note 1	1.3	K/W
R <sub>th(j-a)</sub>	thermal resistance from junction to ambient	in free air	40	K/W

### Note

- The value of R<sub>th(c-h)</sub> depends on the application (see Fig.3).

### Heatsink design

There are two parameters that determine the size of the heatsink. The first is the rating for the virtual junction temperature and the second is the ambient temperature at which the amplifier must still deliver its full power in the BTL mode.

With a conventional BTL amplifier, the maximum power dissipation with a music-like signal (at each amplifier) will be approximately two times 6.5 W. At a virtual junction temperature of 150 °C and a maximum ambient temperature of 65 °C, R<sub>th(vj-c)</sub> = 1.3 K/W and R<sub>th(c-h)</sub> = 0.2 K/W, the thermal resistance of the heatsink

$$\text{should be: } \frac{150 - 65}{2 \times 6.5} - 1.3 - 0.2 = 5 \text{ K/W}$$

Compared to a conventional BTL amplifier, the TDA1564J has a higher efficiency. The thermal resistance of the heatsink should be:

$$1.7 \left( \frac{145 - 65}{2 \times 6.5} \right) - 1.3 - 0.2 = 9 \text{ K/W}$$

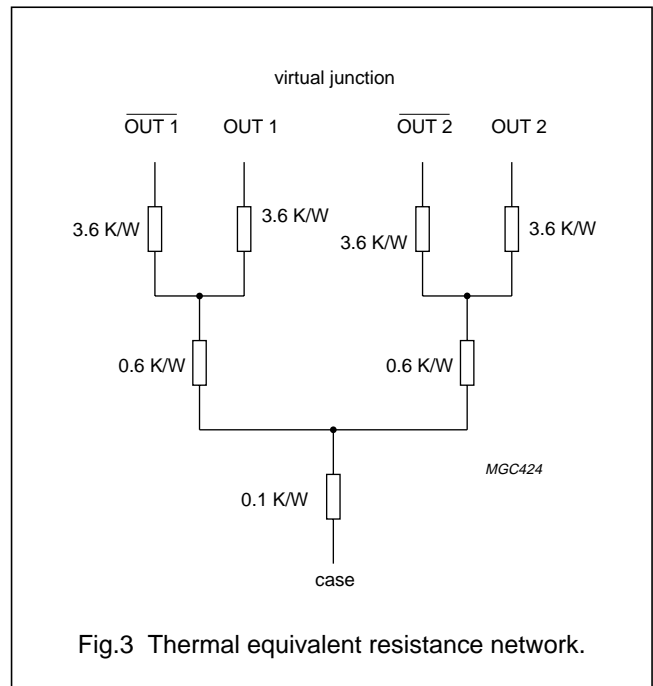

Fig.3 Thermal equivalent resistance network.

## Run-cool stereo power amplifier

TDA1564J

**DC CHARACTERISTICS** $V_P = 14.4\text{ V}$ ;  $T_{\text{amb}} = 25\text{ °C}$ ; measured in Fig.7; unless otherwise specified.

SYMBOL	PARAMETER	CONDITIONS	MIN.	TYP.	MAX.	UNIT
<b>Supplies</b>						
$V_P$	supply voltage	note 1	6.0	14.4	18.0	V
$I_{q(\text{tot})}$	total quiescent current	$R_L = \infty$	–	95	150	mA
$I_{\text{stb}}$	standby current		–	1	50	$\mu\text{A}$
$V_{\text{CSE}}$	average electrolytic capacitor voltage at pin 4		–	7.1	–	V
$ \Delta V_O $	DC output offset voltage	on state	–	–	100	mV
		mute state	–	–	100	mV
<b>Mode select switch</b> (see Fig.4)						
$V_{\text{MODE}}$	voltage at mode select pin	standby condition	0	–	1	V
		mute condition	2	–	3	V
		on condition	4	5	$V_P$	V
$I_{\text{MODE}(\text{sw})}$	switch current through pin 6	$V_{\text{MODE}} = 5\text{ V}$	–	25	40	$\mu\text{A}$
<b>Diagnostic</b>						
$V_{\text{DIAG}}$	output voltage at the diagnostic output pin	$I_{\text{DIAG}} = 2\text{ mA}$ ; during any fault condition or clip detect	–	–	0.5	V
$I_{\text{DIAG}}$	current through the diagnostic pin	during any fault condition or clip detect	2	–	–	mA
$V_{O(\text{DC})}$	DC output voltage detection levels		1.4	2	2.5	V
<b>Protection</b>						
$T_{\text{pre}}$	prewarning temperature		–	145	–	$^{\circ}\text{C}$
$T_{\text{dis}(\text{BTL})}$	BTL disable temperature	note 2	–	150	–	$^{\circ}\text{C}$

**Notes**

1. The circuit is DC biased at  $V_P = 6$  to  $18\text{ V}$  and AC operating at  $V_P = 8$  to  $18\text{ V}$ .
2. If the junction temperature exceeds  $150^{\circ}\text{C}$ , the output power is limited to  $5\text{ W}$  per channel.

Run-cool stereo power amplifier

TDA1564J

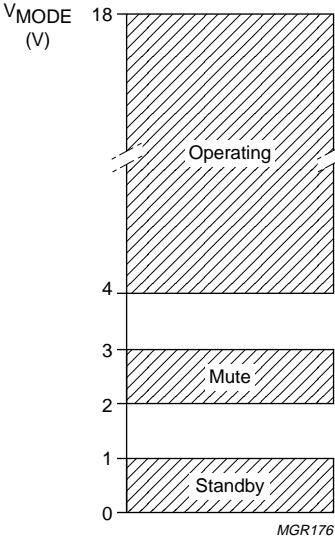

Fig.4 Switching levels of the mode select pin.



## Run-cool stereo power amplifier

## TDA1564J

**AC CHARACTERISTICS**

$V_P = 14.4\text{ V}$ ;  $R_L = 4\ \Omega$ ;  $C_{CSE} = 1000\ \mu\text{F}$ ;  $f = 1\ \text{kHz}$ ;  $T_{\text{amb}} = 25\ ^\circ\text{C}$ ; measured in Fig.7; unless otherwise specified.

SYMBOL	PARAMETER	CONDITIONS	MIN.	TYP.	MAX.	UNIT
$P_o$	output power	THD = 0.5%	15	19	–	W
		THD = 10%	23	25	–	W
		EIAJ	–	38	–	W
		$V_P = 13.2\text{ V}$ ; THD = 0.5%	–	16	–	W
		$V_P = 13.2\text{ V}$ ; THD = 10%	–	20	–	W
THD	total harmonic distortion	$P_o = 1\text{ W}$ ; note 1	–	0.1	–	%
P	power dissipation		see Figs 10 and 11			W
$B_p$	power bandwidth	THD = 1%; $P_o = -1\text{ dB}$ with respect to 15 W	–	20 to 15000	–	Hz
$f_{ro(l)}$	low frequency roll-off	-1 dB; note 2	–	25	–	Hz
$f_{ro(h)}$	high frequency roll-off	-1 dB	130	–	–	kHz
$G_v$	closed-loop voltage gain	$P_o = 1\text{ W}$	25	26	27	dB
SVRR	supply voltage ripple rejection	$R_s = 0\ \Omega$ ; $V_{\text{ripple}} = 2\text{ V}$ (p-p) on/mute	45	65	–	dB
		standby; $f = 100\text{ Hz}$ to 10 kHz	45	–	–	dB
CMRR	common mode rejection ratio	$R_s = 0\ \Omega$	70	90	–	dB
$ Z_i $	input impedance		90	120	150	k $\Omega$
$ \Delta Z_i $	mismatch in input impedance		–	1	–	%
$V_{SE-BTL}$	SE to BTL switch voltage level	note 3	–	3	–	V
$ V_{out} $	output voltage mute (RMS value)	$V_i = 1\text{ V}$ (RMS)	–	100	150	$\mu\text{V}$
$V_{n(o)}$	noise output voltage	on; $R_s = 0\ \Omega$ ; note 4	–	100	150	$\mu\text{V}$
		on; $R_s = 10\ \text{k}\Omega$ ; note 4	–	105	–	$\mu\text{V}$
		mute; note 5	–	100	150	$\mu\text{V}$
$\alpha_{CS}$	channel separation	$R_s = 0\ \Omega$ ; $P_o = 15\text{ W}$	40	70	–	dB
$ \Delta G_v $	channel unbalance		–	–	1	dB

**Notes**

1. The distortion is measured with a bandwidth of 10 Hz to 30 kHz.
2. Frequency response externally fixed (input capacitors determine the low frequency roll-off).
3. The SE to BTL switch voltage level depends on the value of  $V_P$ .
4. Noise output voltage measured with a bandwidth of 20 Hz to 20 kHz.
5. Noise output voltage is independent of  $R_s$ .

Run-cool stereo power amplifier

TDA1564J

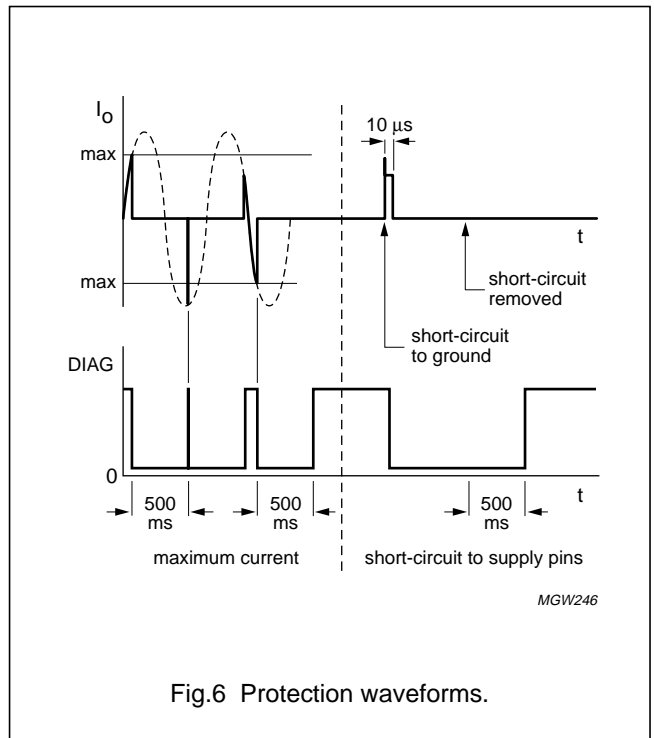
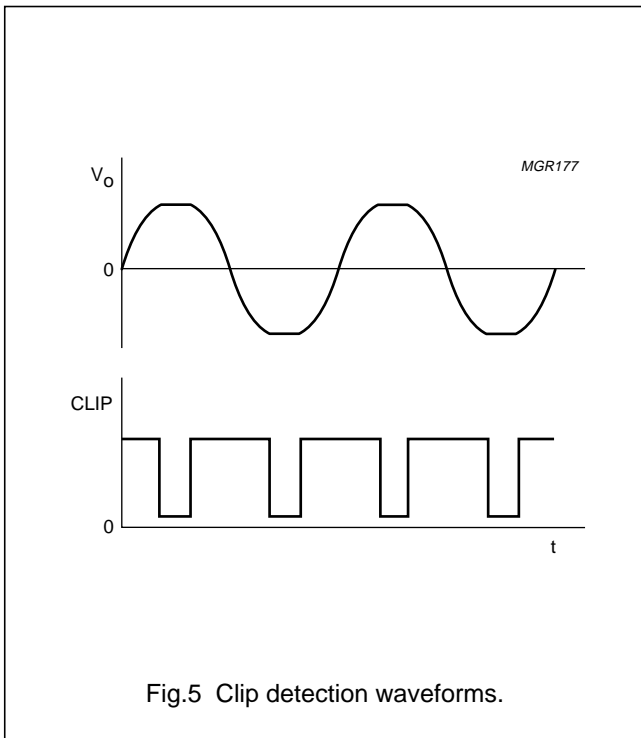

# Run-cool stereo power amplifier

# TDA1564J

## TEST AND APPLICATION INFORMATION

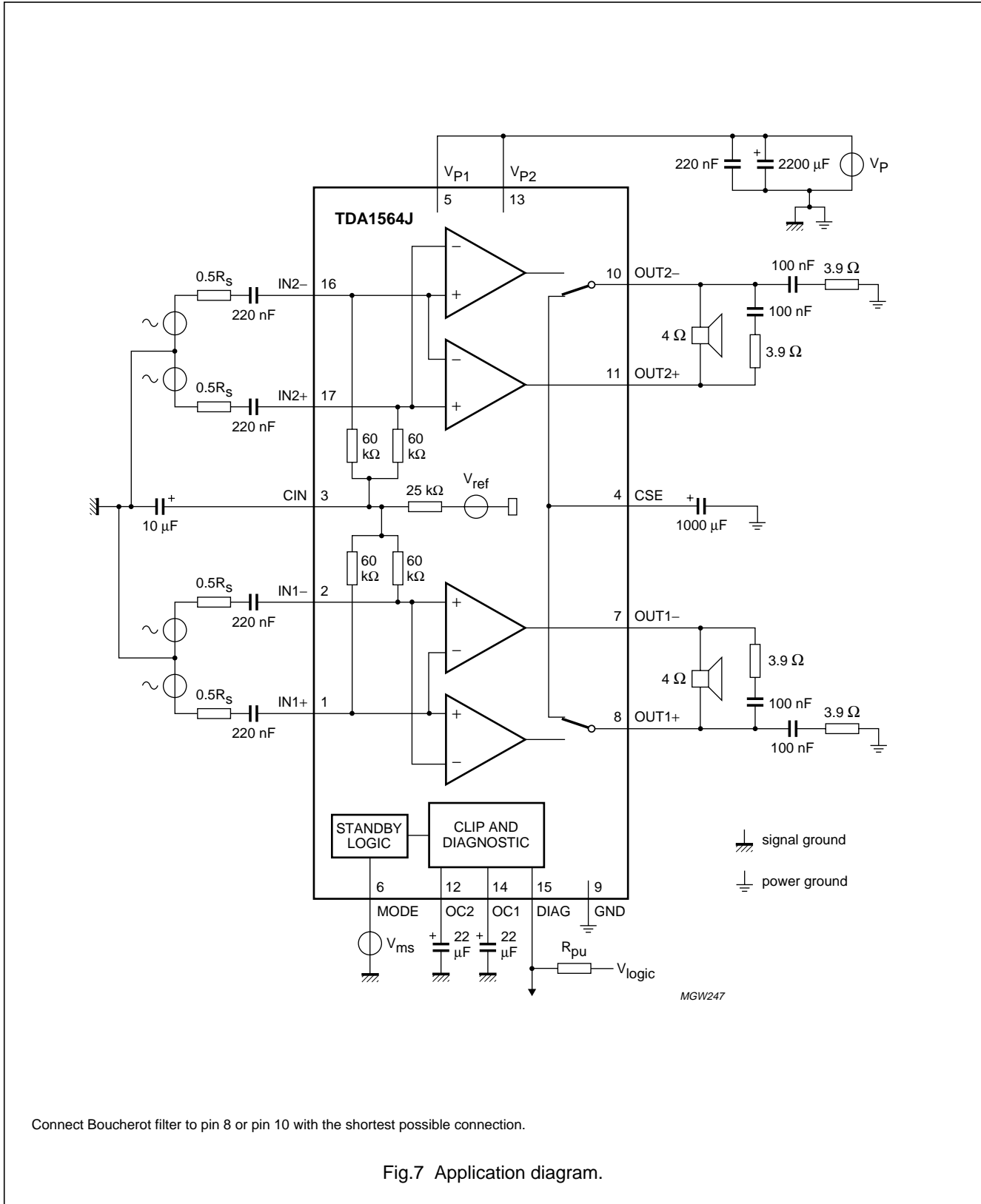

Run-cool stereo power amplifier

TDA1564J

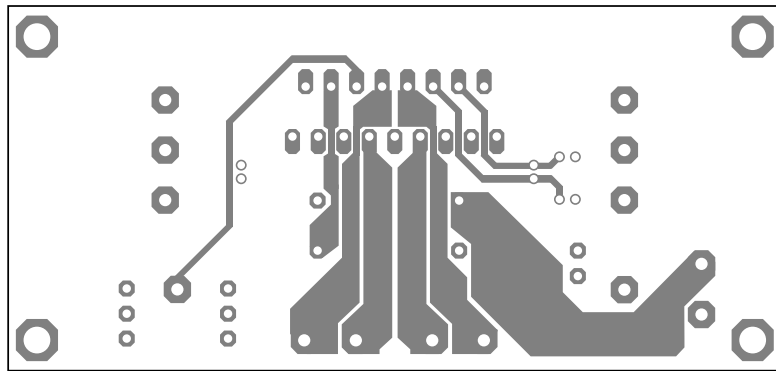
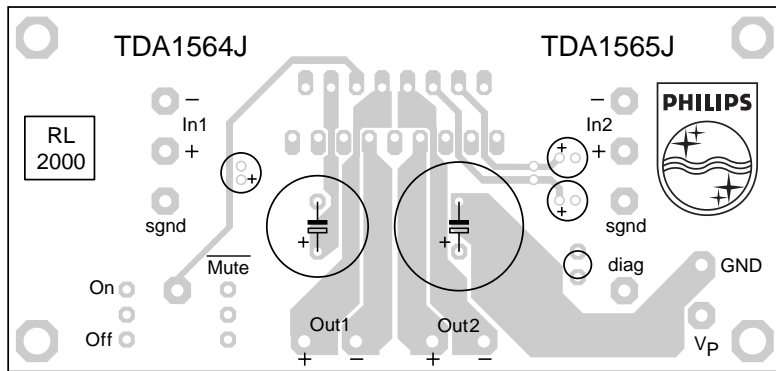

MGW248

Dimensions in mm.

Fig.8 PCB layout (component side) for the application of Fig.7.

Run-cool stereo power amplifier

TDA1564J

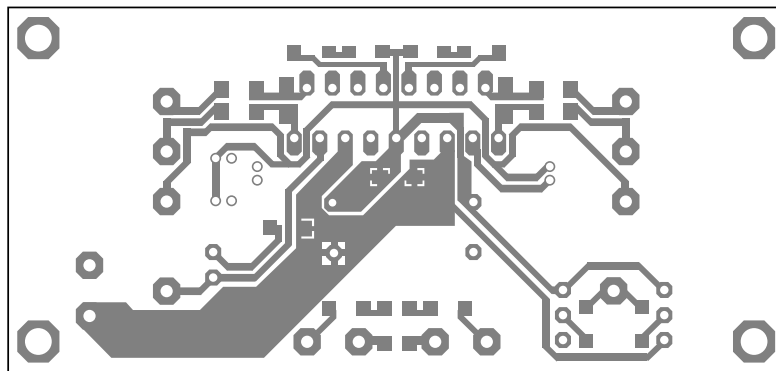
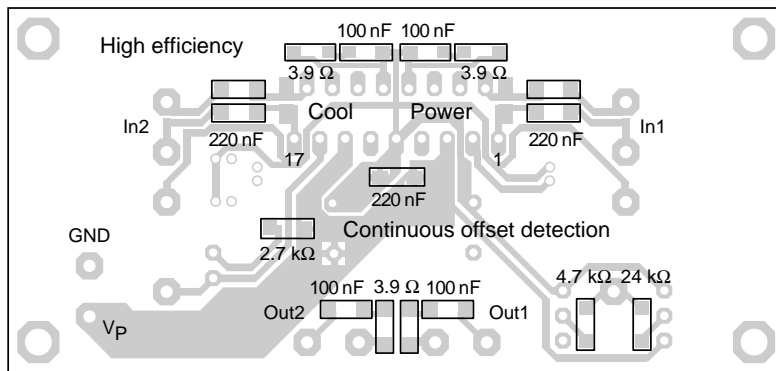

MGW249

Dimensions in mm.

Fig.9 PCB layout (soldering side) for the application of Fig.7.

Run-cool stereo power amplifier

TDA1564J

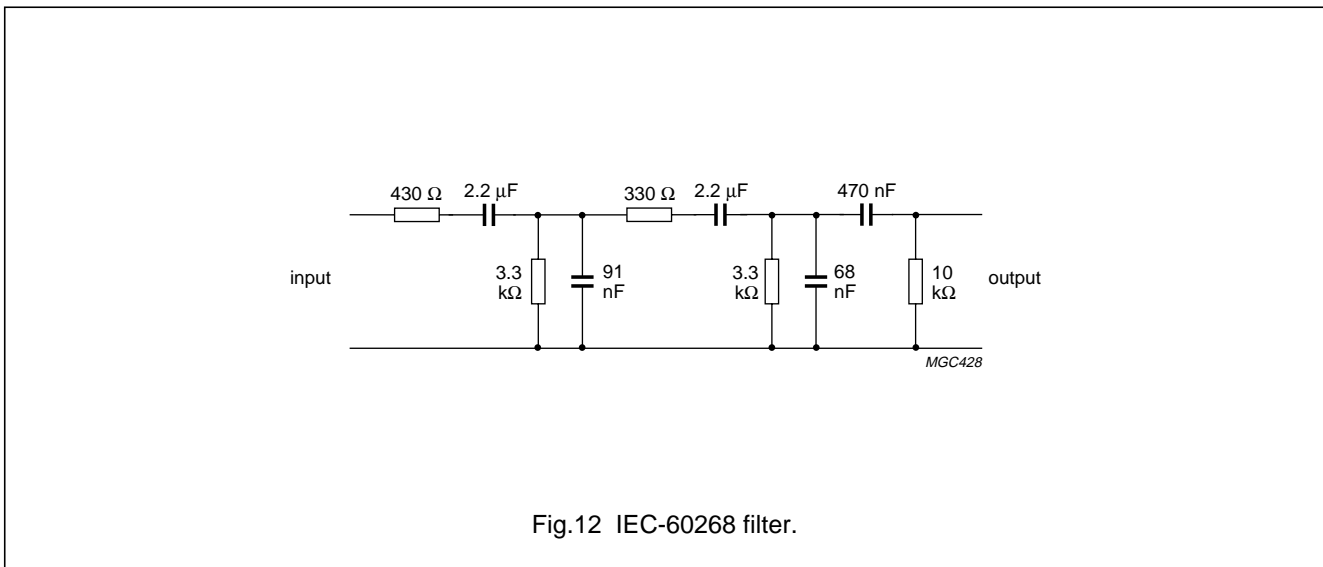
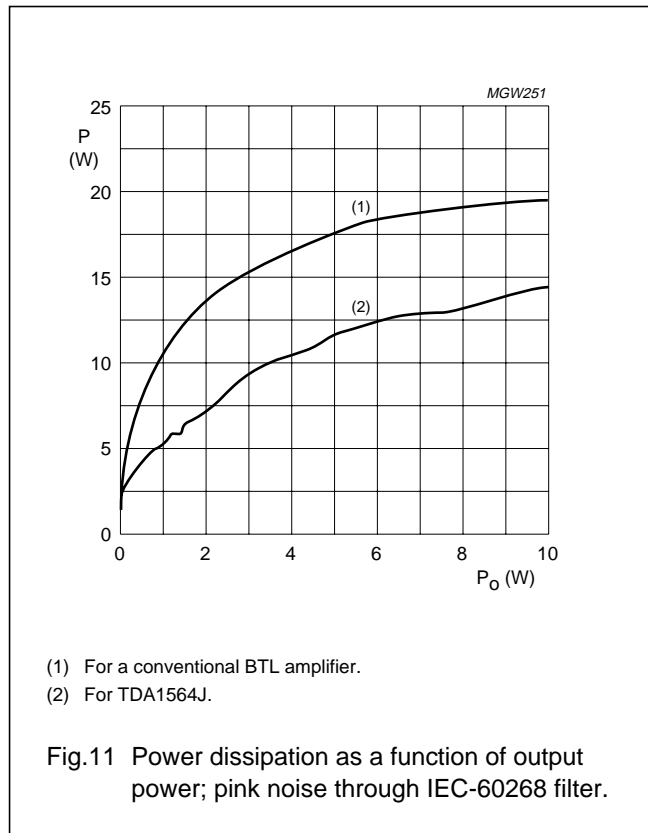
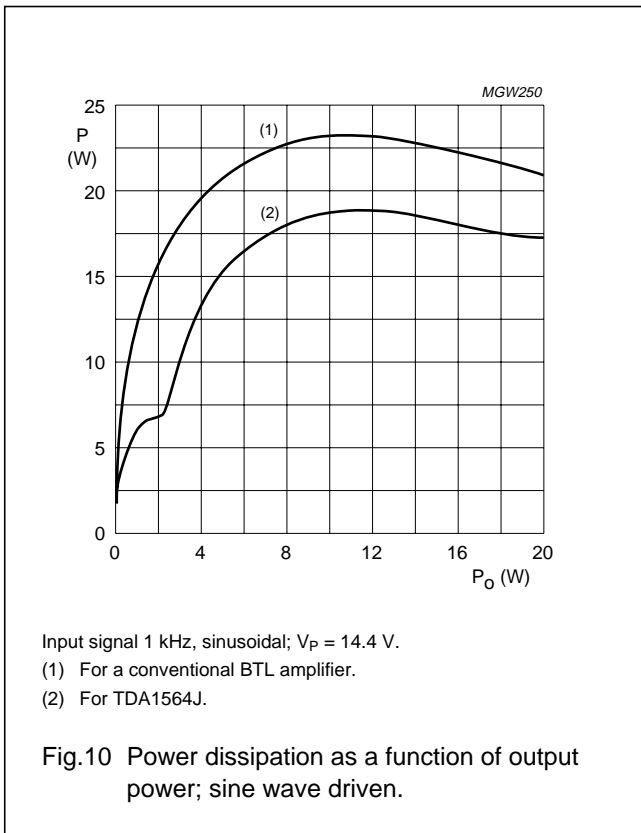

Run-cool stereo power amplifier

TDA1564J

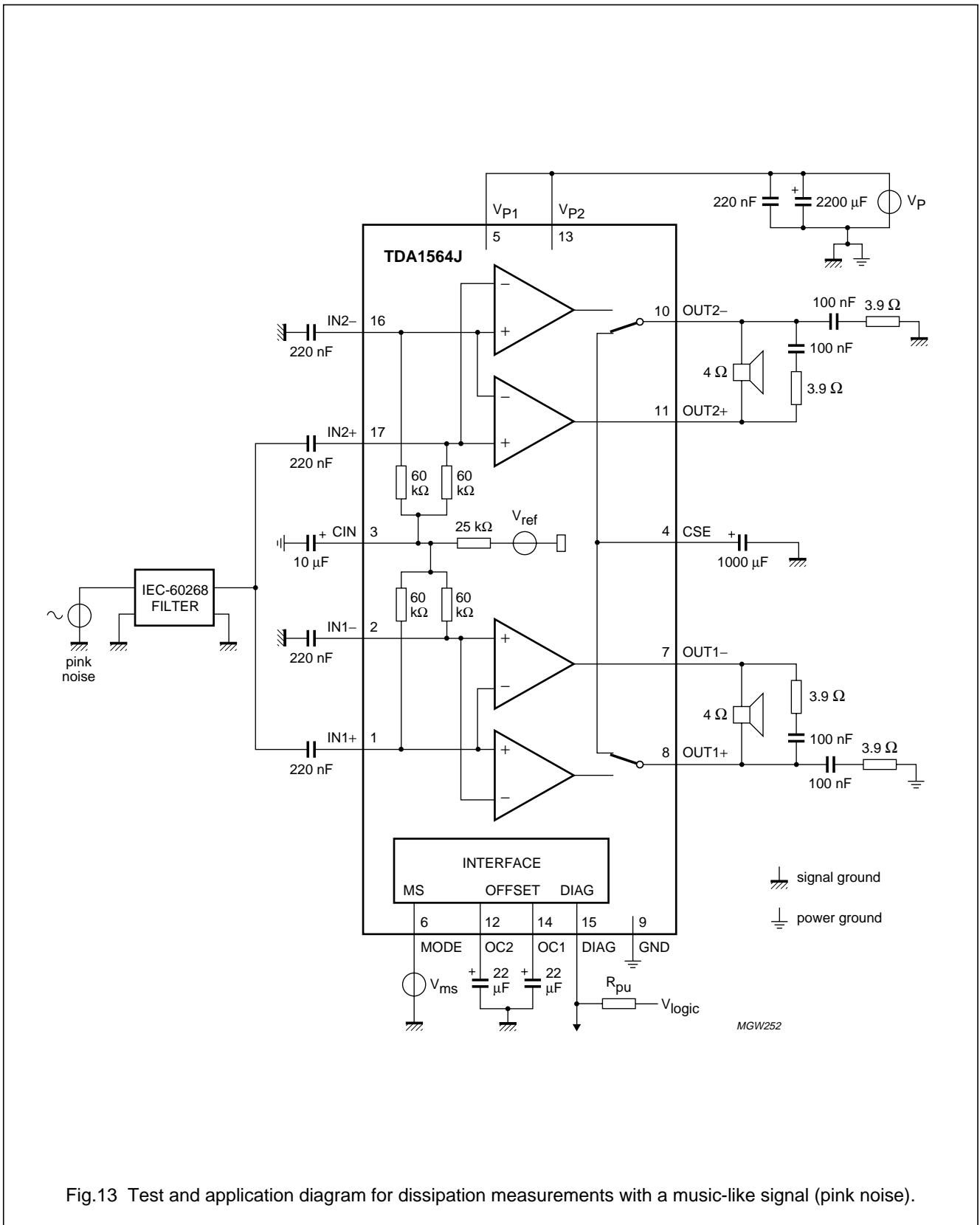
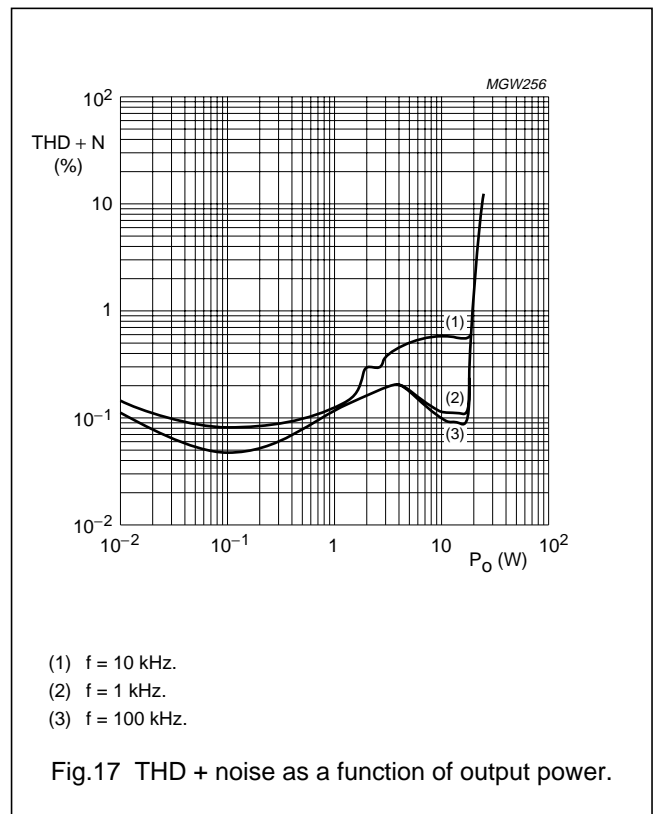
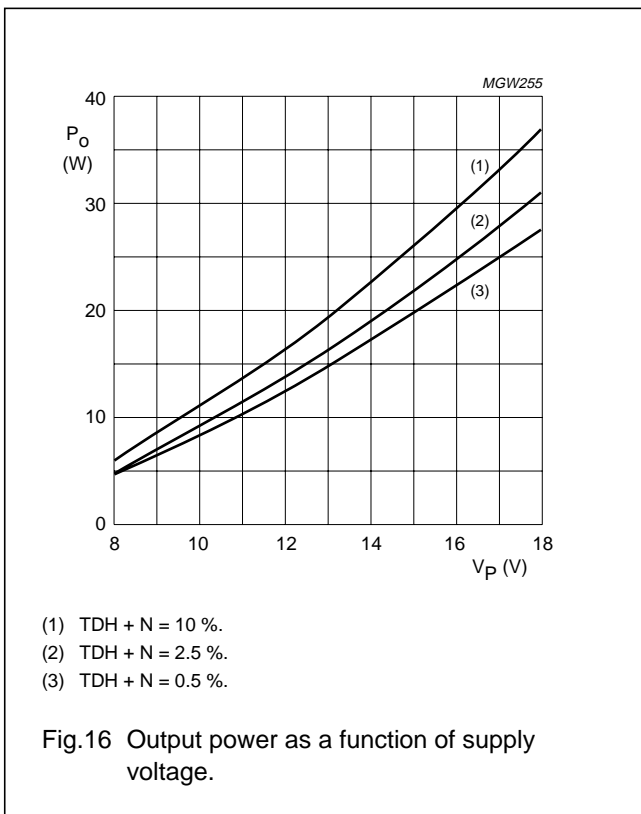
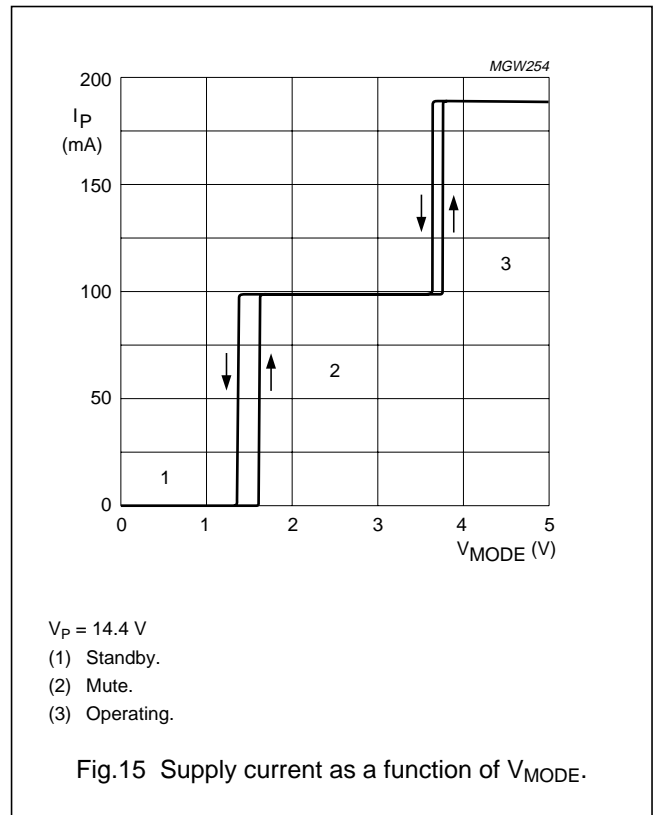
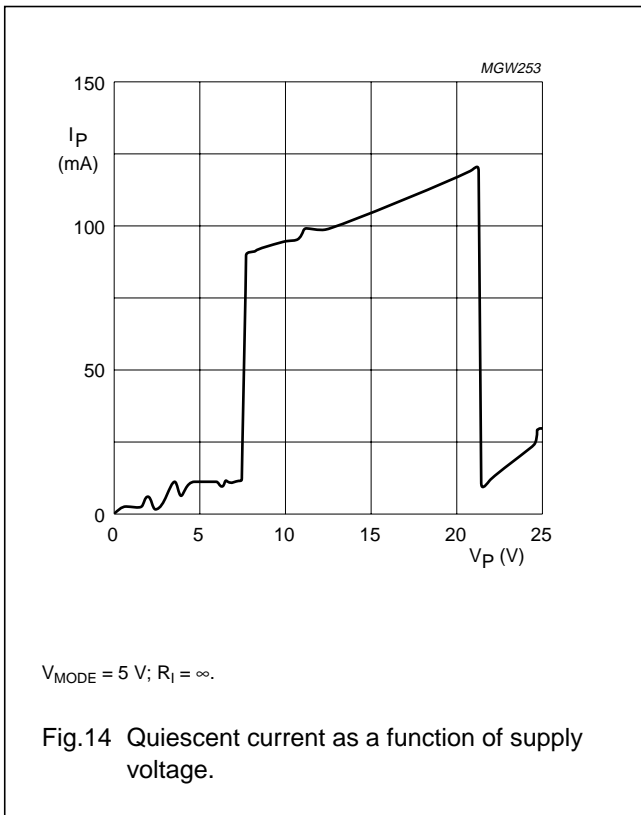

Fig.13 Test and application diagram for dissipation measurements with a music-like signal (pink noise).

Run-cool stereo power amplifier

TDA1564J





Run-cool stereo power amplifier

TDA1564J

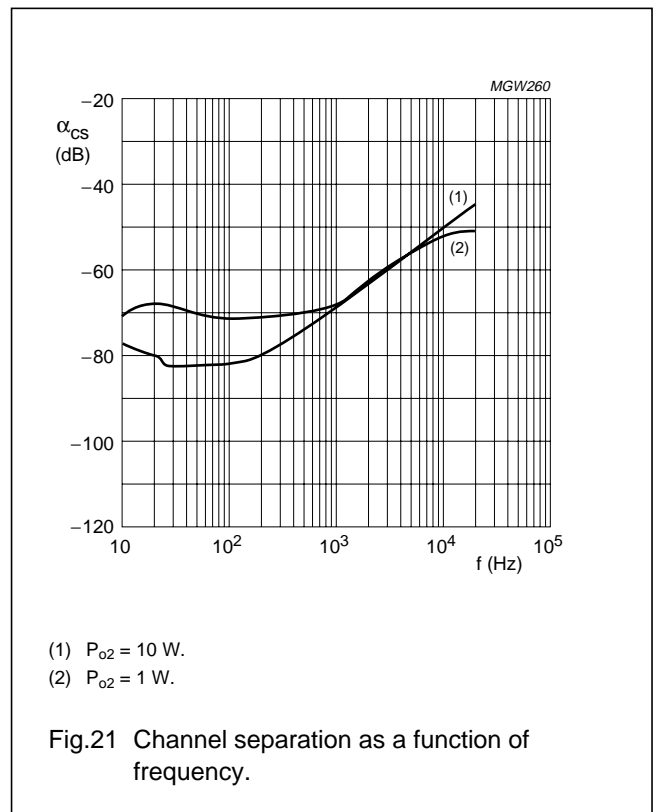
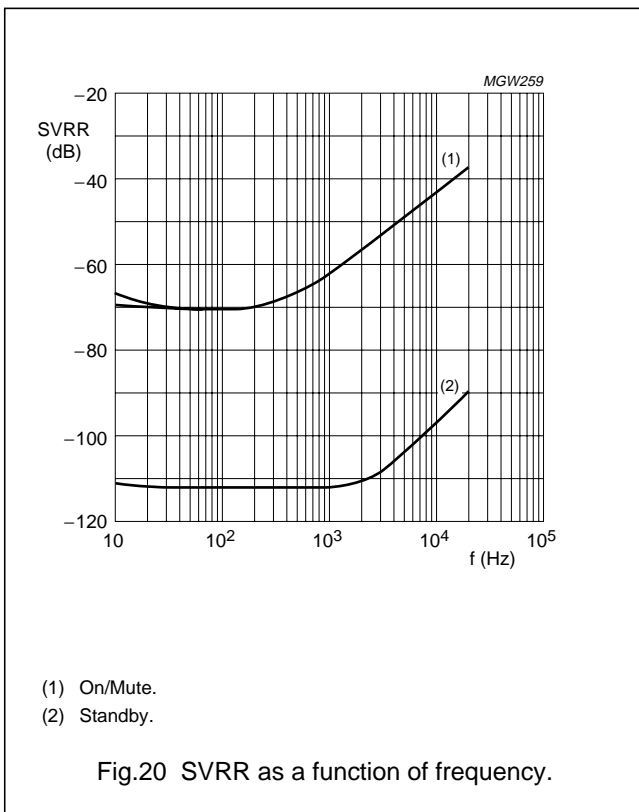
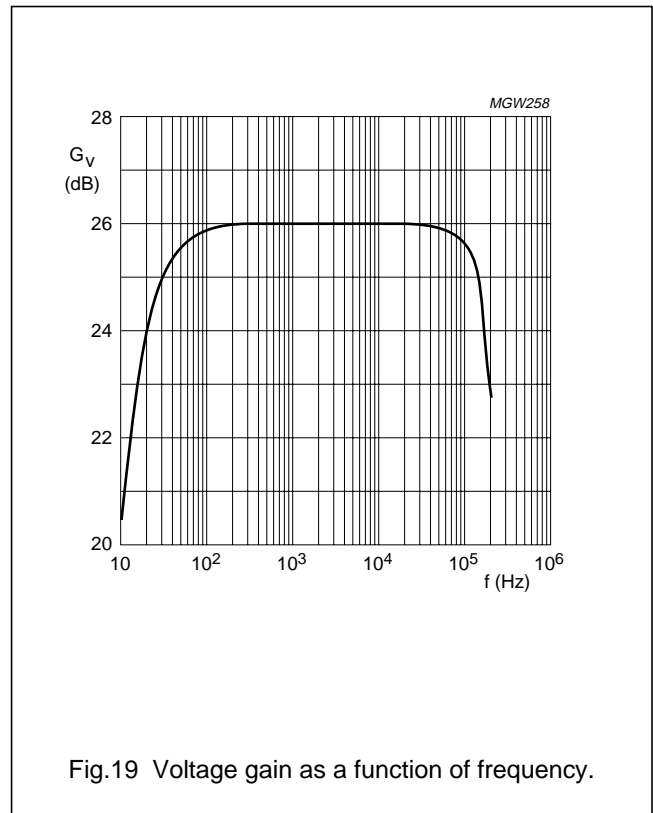
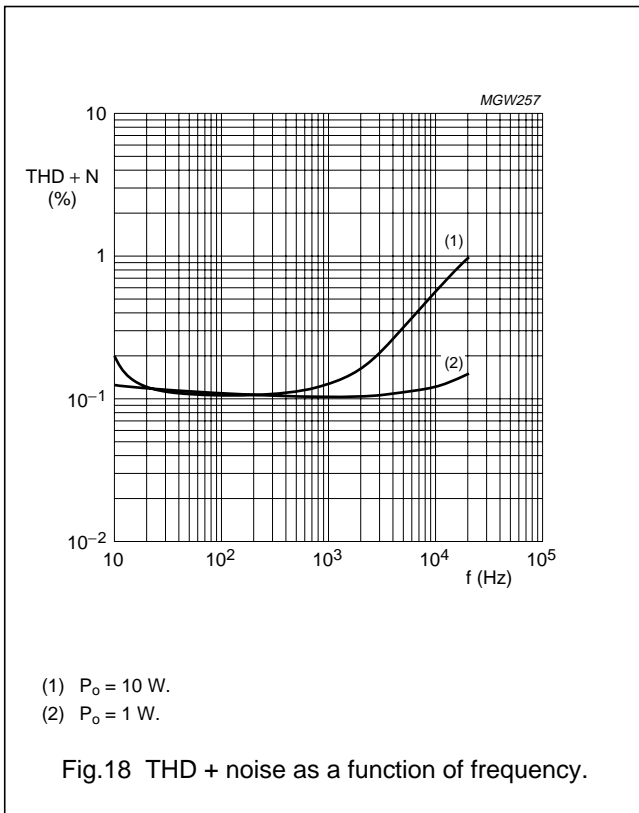

Run-cool stereo power amplifier

TDA1564J

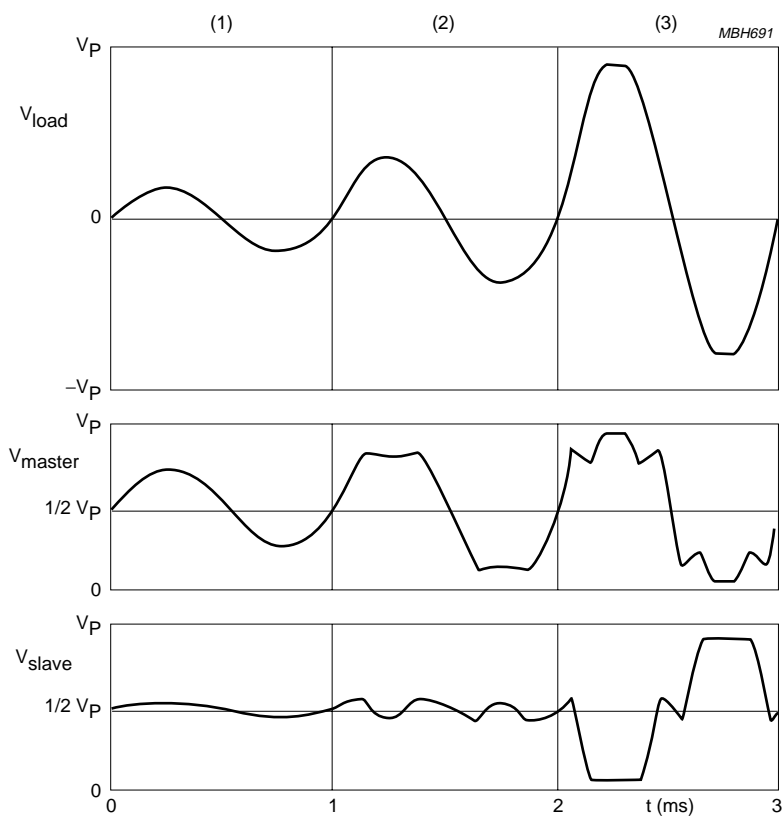

See Fig.7:

$$V_{load} = V_7 - V_8 \text{ or } V_{11} - V_{10}$$

$$V_{master} = V_7 \text{ or } V_{11}$$

$$V_{slave} = V_8 \text{ or } V_{10}$$

Fig.22 Output waveforms.

# Run-cool stereo power amplifier

# TDA1564J

## APPLICATION NOTES

### Advantages of high efficiency

1. Power conversion improvement (power supply): Usually, the fact that the reduction of dissipation is directly related to supply current reduction, is neglected. One advantage is less voltage drop in the whole supply chain. Another advantage is less stress for the coil in the supply line. Even the adapter or supply circuit remains cooler than before due to the reduced heat dissipation in the whole chain because more supply current will be converted into output power.
2. Power dissipation reduction: This is the best known advantage of high efficiency amplifiers.
3. Heatsink size reduction: The heatsink size of a conventional amplifier may be reduced with approximately 50% at  $V_p=14.4V$  when the TDA1564J will be used. In that case, the maximum heatsink temperature will remain the same.
4. Heatsink temperature reduction: The power dissipation and the thermal resistance of the heatsink determine the heatsink temperature rise.

When the same heatsink size is used from a conventional amplifier, the maximum heatsink temperature decreases and also the maximum junction temperature, which extends the life of this semiconductor device. The maximum dissipation with music-like input signals decreases by 40%.

It is clear that the use of the TDA1564J saves a significant amount of energy. The maximum supply current decreases by approximately 32%, that reduces the dissipation in the amplifier as well as in the whole supply chain. The TDA1564J allows a heatsink size reduction of approximately 50% or the heatsink temperature decreases by 40% when the heatsink size hasn't been changed.

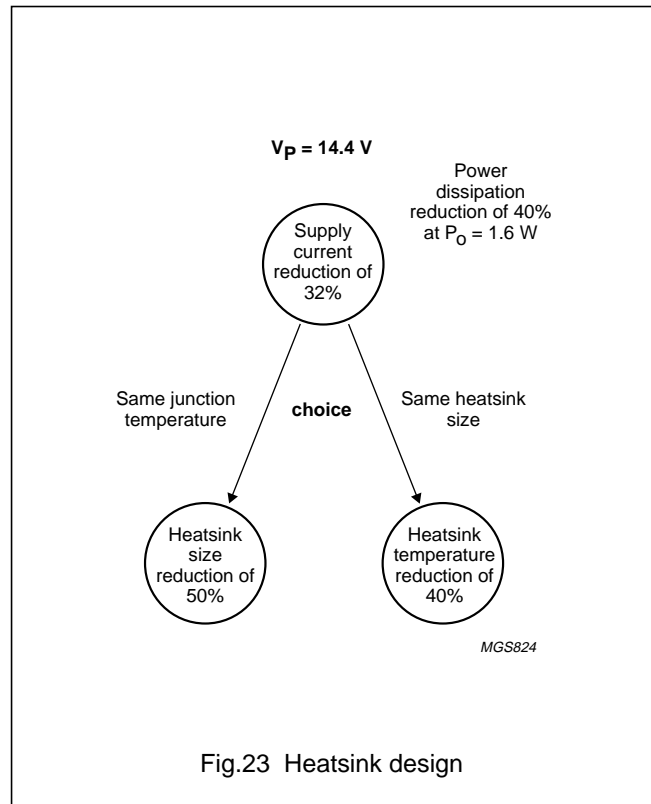

Fig.23 Heatsink design

### Advantage of the concept used by TDA1564J

The TDA1564J is highly efficient under all conditions, because it uses a single-ended capacitor to create a non-dissipating half supply voltage. Other concepts rely on the fact that both input signals are the same in amplitude and phase. With the concept of a SE capacitor it means that it doesn't matter what kind of signal processing is done on the input signals. For example, amplitude difference, phase shift or delays between both input signals, or other DSP processing, have no impact on the efficiency.

Run-cool stereo power amplifier

TDA1564J

INTERNAL PIN CONFIGURATIONS

PIN	NAME	EQUIVALENT CIRCUIT
1, 2, 16, 17 and 3	IN1+, IN1-, IN2-, IN2+ and CIN	
4	CSE	
6	MODE	
7, 11	OUT1-, OUT2+	

Run-cool stereo power amplifier

TDA1564J

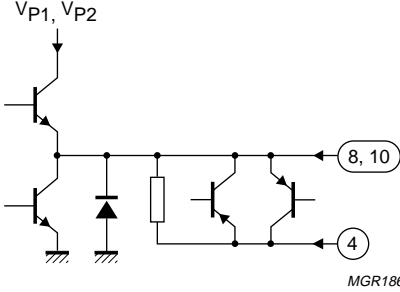
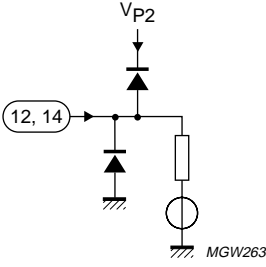
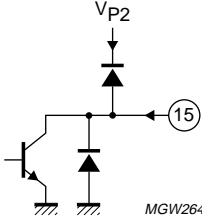
PIN	NAME	EQUIVALENT CIRCUIT
8, 10	OUT1+, OUT2-	
12, 14	OC1, OC2	
15	DIAG	

Run-cool stereo power amplifier

TDA1564J

PACKAGE OUTLINE

DBS17P: plastic DIL-bent-SIL power package; 17 leads (lead length 12 mm)

SOT243-1

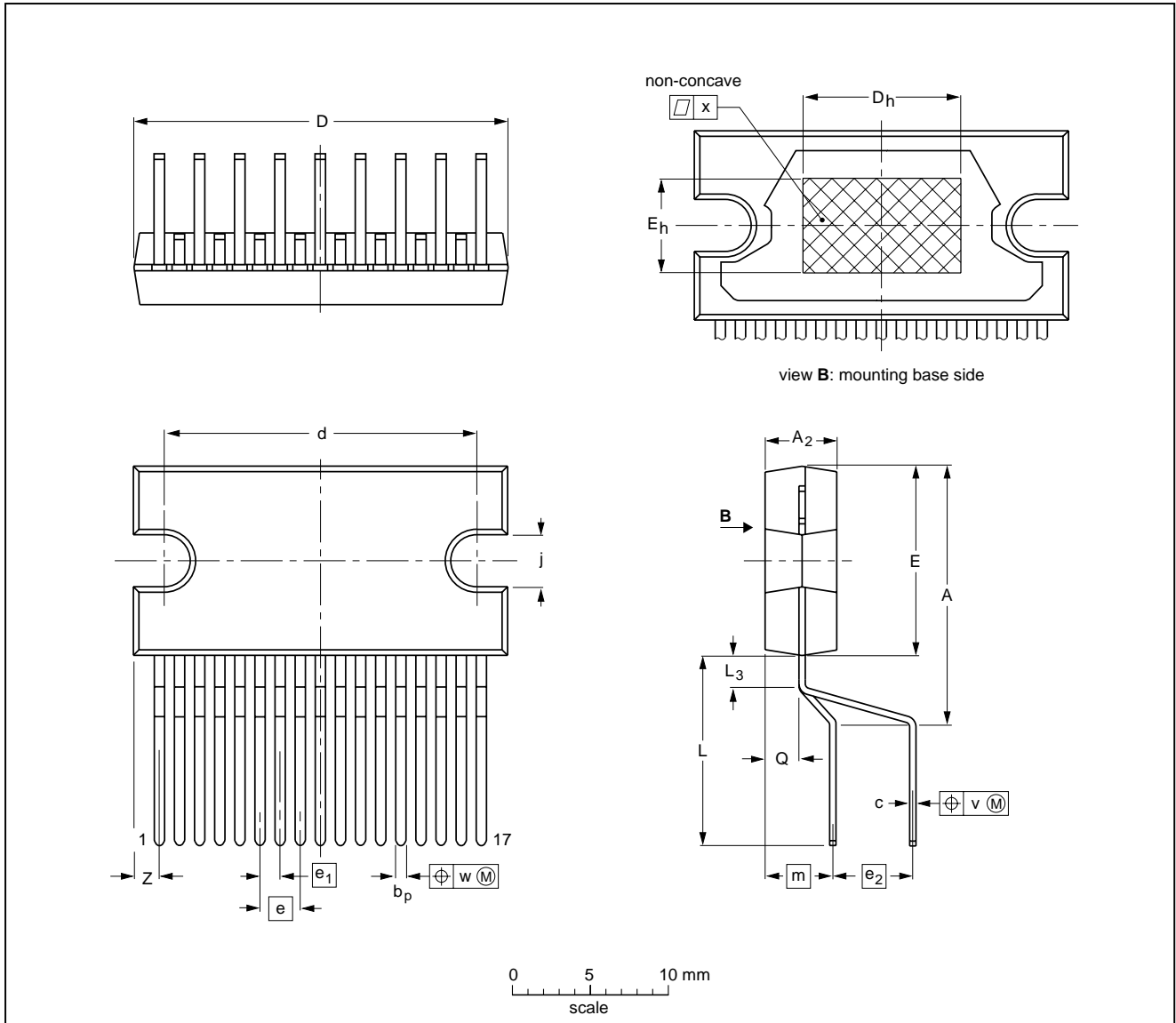

DIMENSIONS (mm are the original dimensions)

UNIT	A	A <sub>2</sub>	b <sub>p</sub>	c	D <sup>(1)</sup>	d	D <sub>h</sub>	E <sup>(1)</sup>	e	e <sub>1</sub>	e <sub>2</sub>	E <sub>h</sub>	j	L	L <sub>3</sub>	m	Q	v	w	x	z <sup>(1)</sup>
mm	17.0 15.5	4.6 4.4	0.75 0.60	0.48 0.38	24.0 23.6	20.0 19.6	10	12.2 11.8	2.54	1.27	5.08	6	3.4 3.1	12.4 11.0	2.4 1.6	4.3	2.1 1.8	0.8	0.4	0.03	2.00 1.45

Note

1. Plastic or metal protrusions of 0.25 mm maximum per side are not included.

OUTLINE VERSION	REFERENCES				EUROPEAN PROJECTION	ISSUE DATE
	IEC	JEDEC	EIAJ			
SOT243-1						97-12-16 99-12-17

## Run-cool stereo power amplifier

## TDA1564J

**SOLDERING****Introduction to soldering through-hole mount packages**

This text gives a brief insight to wave, dip and manual soldering. A more in-depth account of soldering ICs can be found in our *"Data Handbook IC26; Integrated Circuit Packages"* (document order number 9398 652 90011).

Wave soldering is the preferred method for mounting of through-hole mount IC packages on a printed-circuit board.

**Soldering by dipping or by solder wave**

The maximum permissible temperature of the solder is 260 °C; solder at this temperature must not be in contact with the joints for more than 5 seconds.

The total contact time of successive solder waves must not exceed 5 seconds.

The device may be mounted up to the seating plane, but the temperature of the plastic body must not exceed the specified maximum storage temperature ( $T_{stg(max)}$ ). If the printed-circuit board has been pre-heated, forced cooling may be necessary immediately after soldering to keep the temperature within the permissible limit.

**Manual soldering**

Apply the soldering iron (24 V or less) to the lead(s) of the package, either below the seating plane or not more than 2 mm above it. If the temperature of the soldering iron bit is less than 300 °C it may remain in contact for up to 10 seconds. If the bit temperature is between 300 and 400 °C, contact may be up to 5 seconds.

**Suitability of through-hole mount IC packages for dipping and wave soldering methods**

PACKAGE	SOLDERING METHOD	
	DIPPING	WAVE
DBS, DIP, HDIP, SDIP, SIL	suitable	suitable <sup>(1)</sup>

**Note**

- For SDIP packages, the longitudinal axis must be parallel to the transport direction of the printed-circuit board.

## Run-cool stereo power amplifier

TDA1564J

## DATA SHEET STATUS

DATA SHEET STATUS <sup>(1)</sup>	PRODUCT STATUS <sup>(2)</sup>	DEFINITIONS
Objective specification	Development	This data sheet contains data from the objective specification for product development. Philips Semiconductors reserves the right to change the specification in any manner without notice.
Preliminary specification	Qualification	This data sheet contains data from the preliminary specification. Supplementary data will be published at a later date. Philips Semiconductors reserves the right to change the specification without notice, in order to improve the design and supply the best possible product.
Product specification	Production	This data sheet contains data from the product specification. Philips Semiconductors reserves the right to make changes at any time in order to improve the design, manufacturing and supply. Changes will be communicated according to the Customer Product/Process Change Notification (CPCN) procedure SNW-SQ-650A.

## Notes

1. Please consult the most recently issued data sheet before initiating or completing a design.
2. The product status of the device(s) described in this data sheet may have changed since this data sheet was published. The latest information is available on the Internet at URL <http://www.semiconductors.philips.com>.

## DEFINITIONS

**Short-form specification** — The data in a short-form specification is extracted from a full data sheet with the same type number and title. For detailed information see the relevant data sheet or data handbook.

**Limiting values definition** — Limiting values given are in accordance with the Absolute Maximum Rating System (IEC 60134). Stress above one or more of the limiting values may cause permanent damage to the device. These are stress ratings only and operation of the device at these or at any other conditions above those given in the Characteristics sections of the specification is not implied. Exposure to limiting values for extended periods may affect device reliability.

**Application information** — Applications that are described herein for any of these products are for illustrative purposes only. Philips Semiconductors make no representation or warranty that such applications will be suitable for the specified use without further testing or modification.

## DISCLAIMERS

**Life support applications** — These products are not designed for use in life support appliances, devices, or systems where malfunction of these products can reasonably be expected to result in personal injury. Philips Semiconductors customers using or selling these products for use in such applications do so at their own risk and agree to fully indemnify Philips Semiconductors for any damages resulting from such application.

**Right to make changes** — Philips Semiconductors reserves the right to make changes, without notice, in the products, including circuits, standard cells, and/or software, described or contained herein in order to improve design and/or performance. Philips Semiconductors assumes no responsibility or liability for the use of any of these products, conveys no licence or title under any patent, copyright, or mask work right to these products, and makes no representations or warranties that these products are free from patent, copyright, or mask work right infringement, unless otherwise specified.



Run-cool stereo power amplifier

TDA1564J

---

**NOTES**

Run-cool stereo power amplifier

TDA1564J

---

**NOTES**

Run-cool stereo power amplifier

TDA1564J

---

**NOTES**

# ***Philips Semiconductors – a worldwide company***

## **Contact information**

For additional information please visit <http://www.semiconductors.philips.com>. Fax: +31 40 27 24825

For sales offices addresses send e-mail to: [sales.addresses@www.semiconductors.philips.com](mailto:sales.addresses@www.semiconductors.philips.com).

© Koninklijke Philips Electronics N.V. 2002

SCA74

All rights are reserved. Reproduction in whole or in part is prohibited without the prior written consent of the copyright owner.

The information presented in this document does not form part of any quotation or contract, is believed to be accurate and reliable and may be changed without notice. No liability will be accepted by the publisher for any consequence of its use. Publication thereof does not convey nor imply any license under patent- or other industrial or intellectual property rights.

Printed in The Netherlands

753503/01/pp28

Date of release: 2002 Jan 14

Document order number: 9397 750 08362

*Let's make things better.*

**Philips  
Semiconductors**



**PHILIPS**