



MOCZ500

Motorola Preferred Device

Mini Zero-Crossing AC SSR

This device consists of a gallium arsenide infrared emitting diode optically coupled to a zero-cross triac circuit and a power triac. It is capable of driving loads up to 500 mA rms on AC voltages from 20 to 280 V rms.

- Provides Normally Open AC Output with 500 mA Rating @ 40°C
- Small Outline, Standard 6-PIN DIP Package
- Simplified Logic Control of 240 Vac Power
- High Input-Output Isolation of 7500 Vac (rms)
- 7 Amp Single Cycle Surge Capability
- Wide Load Power Factor Range 0.1-1
- Low Input/Output Capacitance

Applications:

- Logic to AC Line Interface
- Microprocessor to AC Line Peripheral
- Industrial Controls
- EM Relays and Contactors
- Small AC Motor Drives
- Incandescent Lamp Drive
- Appliance Solenoids
- Appliance Actuators
- Appliance Fan Motors
- Appliance Lights

MAXIMUM RATINGS (T_A = 25°C unless otherwise noted)

| Rating | Symbol | Value | Unit |
|------------------------------|----------------|-------|------|
| INPUT LED | | | |
| Reverse Voltage | V _R | 6 | V |
| Forward Current — Continuous | I _F | 50 | mA |

OUTPUT TRIAC

| | | | |
|---|---------------------|----------------|--------------------|
| Off-State Output Terminal Voltage (1) | V _{DRM} | 600 | V |
| Peak Repetitive Surge Current (1 Cycle) | I _{TSM} | 7 | A |
| Main Terminal Fusing Current (t = 8.3 ms) | i ² T | 0.4 | A ² sec |
| On-State Current Range | I _{T(rms)} | 0.030 to 0.500 | A |
| Load Power Factor Range | pF | 0.1 – 1.0 | — |

TOTAL DEVICE

| | | | |
|---|------------------|-------------|---------|
| Isolation Surge Voltage (2) | V _{ISO} | 7500 | Vac(pk) |
| Total Power Dissipation @ T _A = 40°C (Device Soldered on PCB) | P _D | 600 | mW |
| Junction Temperature Range | T _J | -40 to +125 | °C |
| Ambient Operating Temperature Range | T _A | -40 to +85 | °C |
| Ambient Operating Relative Humidity @ T _A = 85°C | RH _A | 85 | % |
| Storage Temperature Range | T _{stg} | -40 to +125 | °C |
| Soldering Temperature (10 sec) | T _L | 260 | °C |

1. Test voltages must be applied within dv/dt rating.
2. Input-Output isolation voltage, V_{ISO}, is an internal device dielectric breakdown rating. For this test, pins 1 and 2 are common and pins 4 and 6 are common.

Preferred devices are Motorola recommended choices for future use and best overall value.

OPTOISOLATOR ZERO CROSS TRIAC OUTPUT

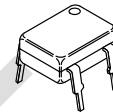

CASE 730J-01
STYLE 1

PINOUT

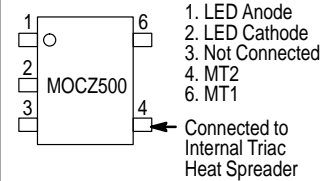

COUPLER SCHEMATIC

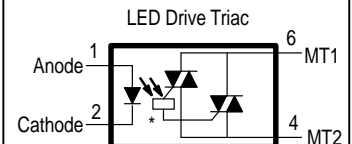

*ZERO VOLTAGE
ACTIVATION

MOCZ500

THERMAL CHARACTERISTICS

| Characteristic | Symbol | Value | Unit |
|--|-----------------|-------|-----------------------------|
| Thermal Resistance, Junction to Air (Device Soldered on PCB) | $R_{\theta JA}$ | 130 | $^{\circ}\text{C}/\text{W}$ |
| Thermal Resistance, Junction to Case (Pin 4) (Device Soldered on PCB) | $R_{\theta JC}$ | 40 | $^{\circ}\text{C}/\text{W}$ |

ELECTRICAL CHARACTERISTICS ($T_A = 25^{\circ}\text{C}$ unless otherwise noted)

| Characteristic | Symbol | Min | Typ | Max | Unit |
|----------------|--------|-----|-----|-----|------|
|----------------|--------|-----|-----|-----|------|

INPUT LED

| | | | | | |
|--|-------|---|------|-----|---------------|
| Reverse Leakage Current ($V_R = 6\text{ V}$) | I_R | — | 0.05 | 100 | μA |
| Forward Voltage ($I_F = 10\text{ mA}$) | V_F | — | 1.2 | 1.5 | V |

OUTPUT TRIAC

| | | | | | |
|---|------------|---|-------|-----|------------------------|
| Leakage with LED Off @ $T_A = 85^{\circ}\text{C}$ ($V_{DRM} = 600\text{ V}$) | I_{DRM} | — | — | 100 | μA |
| Critical Rate of Rise of Off-State Voltage (Static) (1) ($V_p = 400\text{ V}$) | $dv/dt(s)$ | — | 2,000 | — | $\text{V}/\mu\text{s}$ |
| LED On, Driver Holding Current | I_{H1} | — | 150 | 500 | μA |

COUPLED

| | | | | | |
|---|--------------|-----------|-----|-----|------------------------|
| LED Trigger Current Required to Latch Output (2) (3) (Main Terminal Voltage = 5 V) | $I_{FT(on)}$ | — | — | 10 | mA |
| On-State Voltage ($I_T = 500\text{ mA}$) | V_{TM} | — | 1.2 | 1.5 | V |
| Inhibit Voltage ($I_F = I_{FT}$) | V_{INH} | — | 10 | 20 | V |
| Commutating dv/dt | $dv/dt(c)$ | 10 | — | — | $\text{V}/\mu\text{s}$ |
| Common-Mode Input-Output dv/dt | $dv/dt(cm)$ | 40,000 | — | — | $\text{V}/\mu\text{s}$ |
| Input-Output Capacitance | C_{ISO} | — | — | 1 | pF |
| Isolation Resistance @ 500 Vdc | R_{ISO} | 10^{12} | — | — | Ohms |

- Additional dv/dt information, including test methods, can be found in Motorola applications note AN1048/D, Figure 40.
- All devices are guaranteed to trigger at as I_F value less than or equal to the max I_{FT} . Therefore, the recommended operating I_F lies between the device's maximum $I_{FT(on)}$ limit and the Maximum Rating of 60 mA.
- Current-limiting resistor required in series with LED.

ENVIRONMENTAL TEST REQUIREMENTS

| Test | Test Conditions |
|---------------------------|---|
| Autoclave | $T_A = 121^{\circ}\text{C}$, RH = 100%, P = 15 PSIG, 48 Hr. |
| Moisture Resistance | Mil-Std-883, Method 1004 |
| Temp Cycle | $T_A = -40/+125^{\circ}\text{C}$, Air to Air, Dwell $\geq 15\text{ min.}$, Transfer $\leq 5\text{ min.}$, 200 Cycles |
| Resistance to Solder Heat | Mil-Std-750, Method 2031, 260°C followed by V_{ISO} |
| Lead Pull | Mil-Std-750, Method 2036, Condition A, 2 lbs., 1 min. |

LIFE TEST REQUIREMENTS

| Test | Test Conditions | | Duration |
|---|--|---|----------|
| | Environment | Bias | |
| High Temperature, Reverse Bias | $T_A = +100^{\circ}\text{C}$ | $V_{TM} = 280\text{ Vac}$ | 1000 Hr. |
| High Humidity, High Temperature, Reverse Bias | $T_A = +85^{\circ}\text{C}$ RH = 85% | $V_{TM} = 100\text{ Vdc}$ Pin 4 = + Pin 6 = - | 500 Hr. |
| Intermittent Operating Life | $t_{on} = 2\text{ min.}$ $t_{off} = 2\text{ min.}$ $T_A = +25^{\circ}\text{C}$ | $I_F = 50\text{ mA}$ $I_{TM} = 60\text{ mA}$ | 1000 Hr. |
| ESD | Human Body Model & Machine Models 1 & 2 | N/A | N/A |

TYPICAL ELECTRICAL CHARACTERISTICS

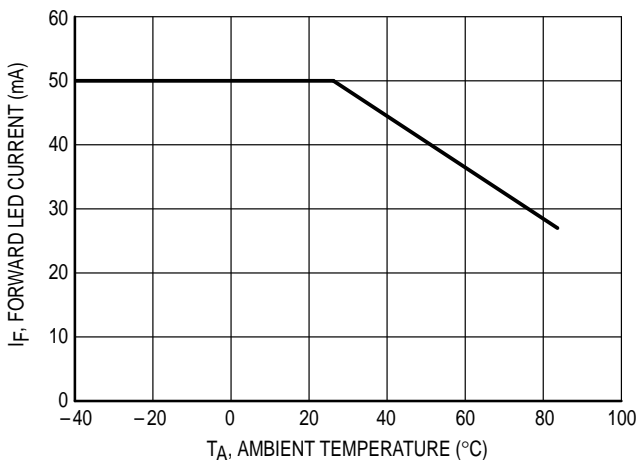

Figure 1. Maximum Allowable Forward LED Current versus Ambient Temperature
 $I_T = I_T \text{ Max}$

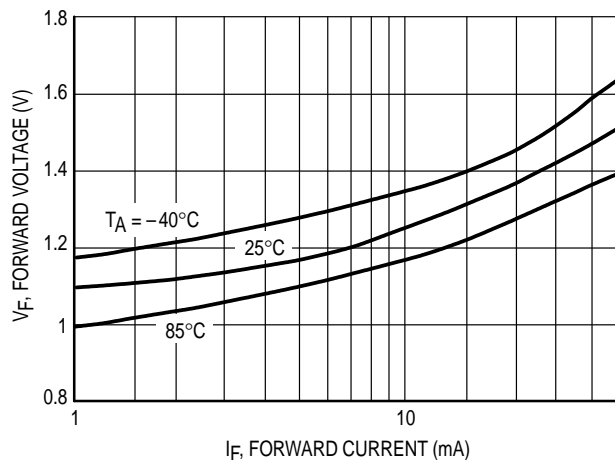

Figure 2. LED Forward Voltage versus LED Forward Current

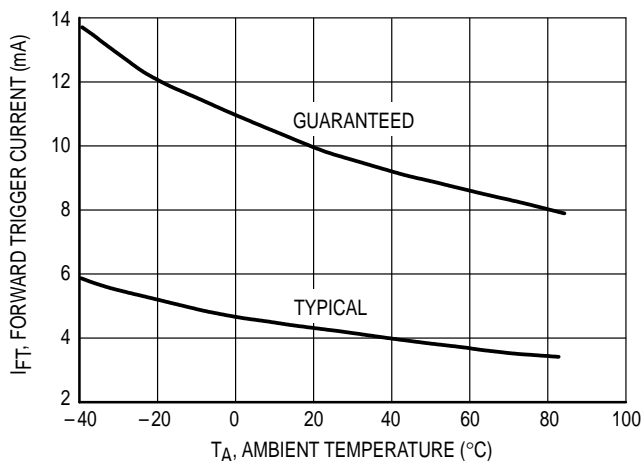

Figure 3. Forward Trigger Current versus Ambient Temperature

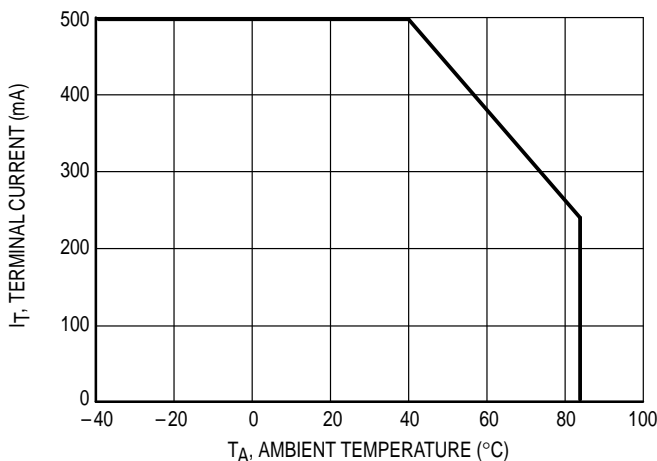

Figure 4. RMS ON-State Current versus Ambient Temperature

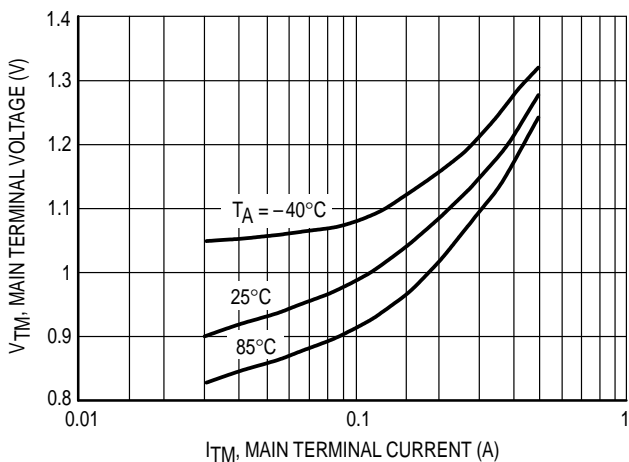

Figure 5. Main Terminal Voltage versus Main Terminal Current

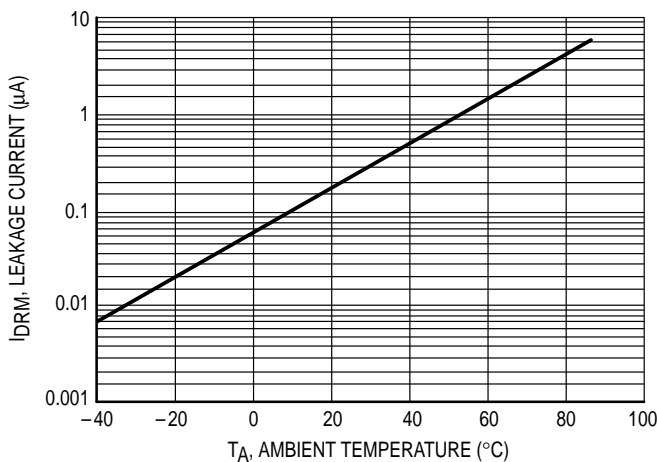

Figure 6. Typical Leakage Current versus Ambient Temperature

TYPICAL ELECTRICAL CHARACTERISTICS (continued)

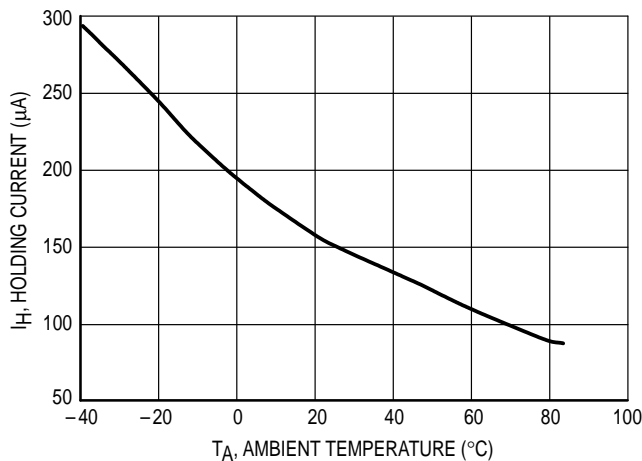

Figure 7. Holding Current versus Ambient Temperature

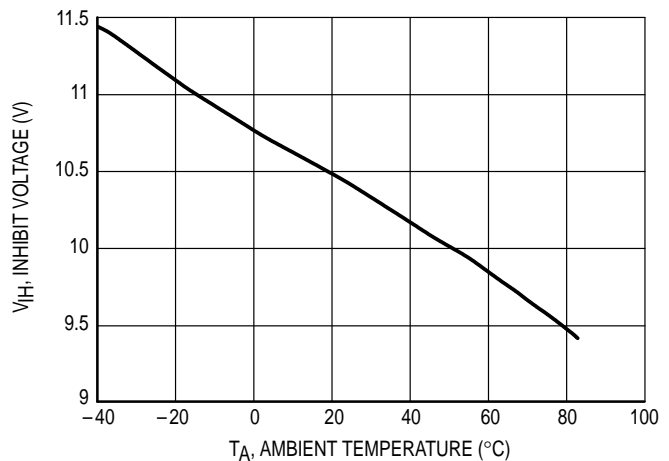

Figure 8. Inhibit Voltage versus Ambient Temperature

APPLICATION CONSIDERATIONS

Input Drive Circuit

The MOCZ500 SSR is guaranteed to trigger with an input current of 10 mA at 25°C. This trigger current increases with lower ambient temperatures as shown on Figure 3 Forward Trigger Current (I_{FT}) versus Ambient Temperature.

When the input drive circuit is capable to supply the MOCZ500 input LED trigger current, only a current limiting resistor in series with the LED is required. TTL, DTL and microcontrollers with enhanced current capability output ports are able to meet this requirement.

Most CMOS logic circuits and Microcontroller output ports are not rated to sink or source currents required to trigger the MOCZ500. In this case a drive circuit is required as shown in Figure 10 or a TTL buffer interface circuit as shown in Figure 9.

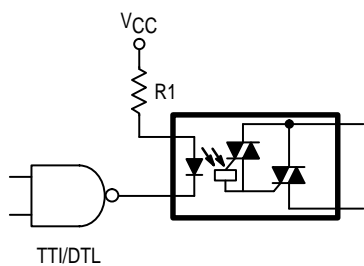

R1 for V_{CC} (low) 4.5 V, I_{FT} = 10 mA, V_F LED = 1.2 V, V_{OL} = 0.5 V
 $R1 = (4.5 V - 1.2 V - 0.5 V) / 10 mA = 280 \Omega$
 Choose 270 Ω

Figure 9. Input Drive Circuit

Snubber Circuit

Snubberless operation of resistive loads is possible, but snubbers are recommended for all applications. A typical application is shown in Figure 11. The snubber attenuates the high kickback voltages and commutating dv/dt generated by inductive loads during the turn off of the SSR. It also protects the SSR from line transients generated elsewhere within the equipment (for example inductive loads switched by mechanical contacts such as relays manual on/off switches etc.) or outside the equipment such as air conditioners, electrical heaters and motors.

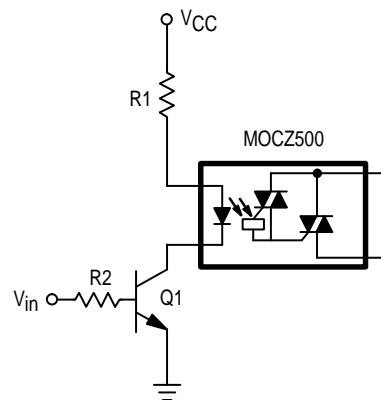
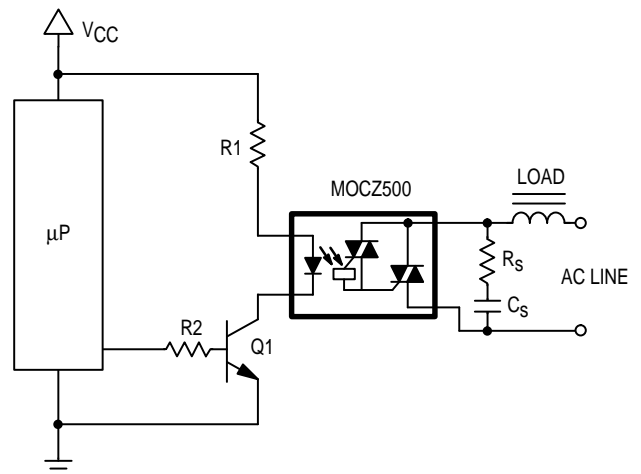

Figure 10. Noninverting Discrete NPN Buffer and Level Shifter



Buffer Circuit
 $R1 = (V_{CC} - V_{FLED} - V_{sat} Q1) / I_F \text{ MOCZ500}$
 $R2 = 10 \text{ k}\Omega$
 $Q1 = \text{General Purpose Trans. NPN}$
 Typical Snubber circuit:
 For inductive and resistive loads $R_s = 45 \Omega$ $C_s = 0.01 \mu\text{F}$

Figure 11. Typical Application with a µP Output Buffer

Snubbers are also necessary to pass noise immunity tests such as IEC1000 4-4 for fast transients. In this test fast rising high voltage spikes are superimposed onto the line voltage to simulate AC line transients.

Switching Loads with Currents Below the Minimum Current Rating

The MOCZ500 is capable to switch any inductive or resistive load within its rating of minimum 30 mA and a maximum of 500 mA RMS.

At operating currents below the minimum specified value the Power triac remains in the off state and the triac driver carries the current. This may cause a problem, because the triac driver has a significant lower commutating dv/dt than the power triac. For loads below 30 mA AC rms a snubber is mandatory. Evaluations with various low current inductive and resistive loads concluded that a snubber of $R = 100 \Omega$ and $C = 10 \text{ nF}$ is sufficient.

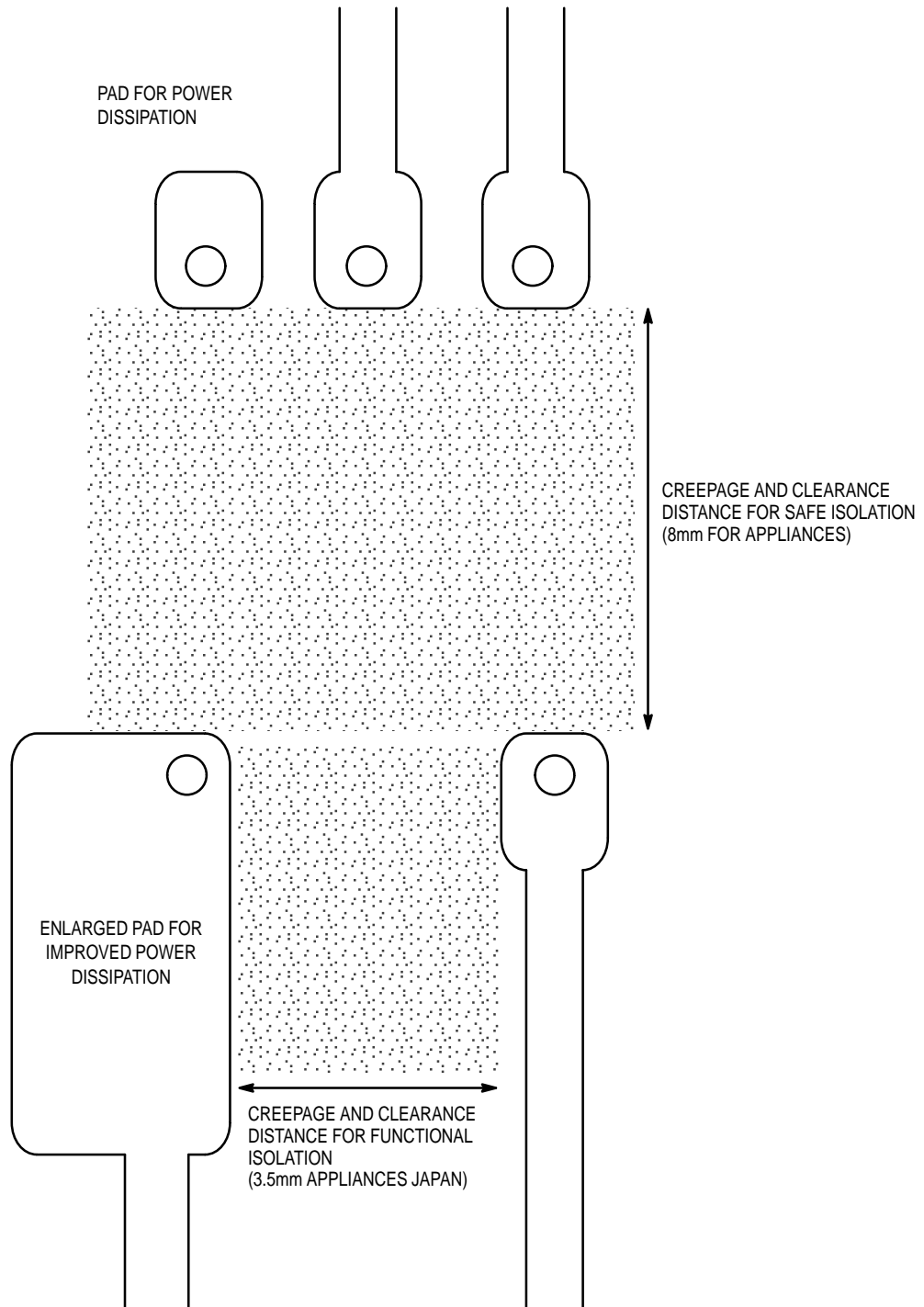

Figure 12.

MOCZ500

Thermal Considerations

Heat generated inside the MOCZ500's power triac is transferred through the leads to the circuit board where it is dissipated. It is therefore important to solder all leads to the circuit board. Pin 4 is thermally and electrically direct connected to the Power triac and carries the highest amount of thermal energy. For loads which approach the maximum current rating of the SSR it is advisable to layout the pad size for pin 4 as large as possible. See Figure 12 which considers thermal and Regulatory requirements on a PCB.

Regulatory Safety Considerations

The MOCZ500 is designed to meet the National and International Regulatory requirements for safe isolation

between input and output and functional isolation creepage and clearance distances between the AC output pins.

Many equipment standards demand a creepage and clearance distance between input and output circuit of 8mm and a thickness through insulation of 0.4mm (16 mil). All Motorola Optocouplers do meet the thickness through insulation requirement. Product with lead bend option "T" meets the creepage path requirement. The most stringent requirement for creepage and clearance between the AC output pins is 3.5mm. Figure 12 shows a PCB pattern layout which meets the regulatory requirements for 115 Vrms and 240 Vrms supply line applications.

OUTLINE DIMENSIONS

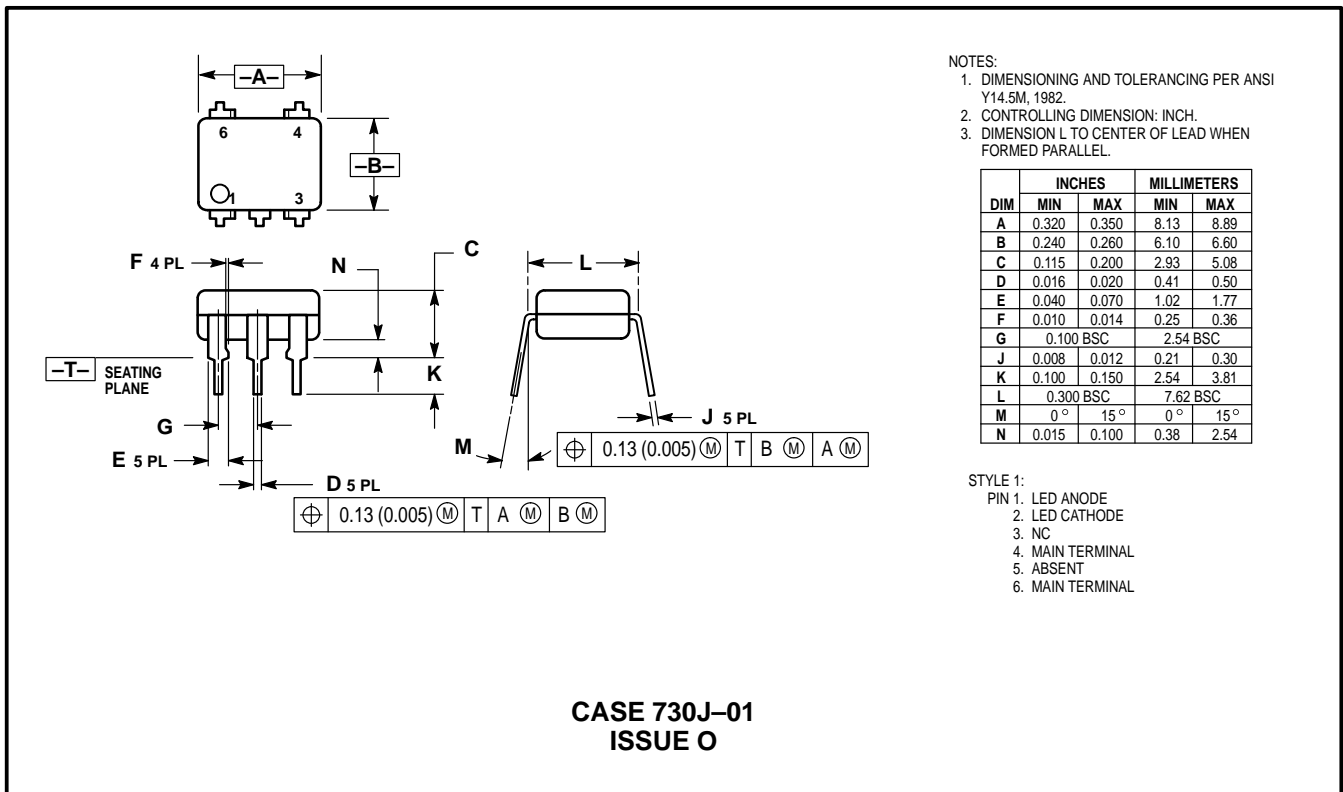

OUTLINE DIMENSIONS (continued)

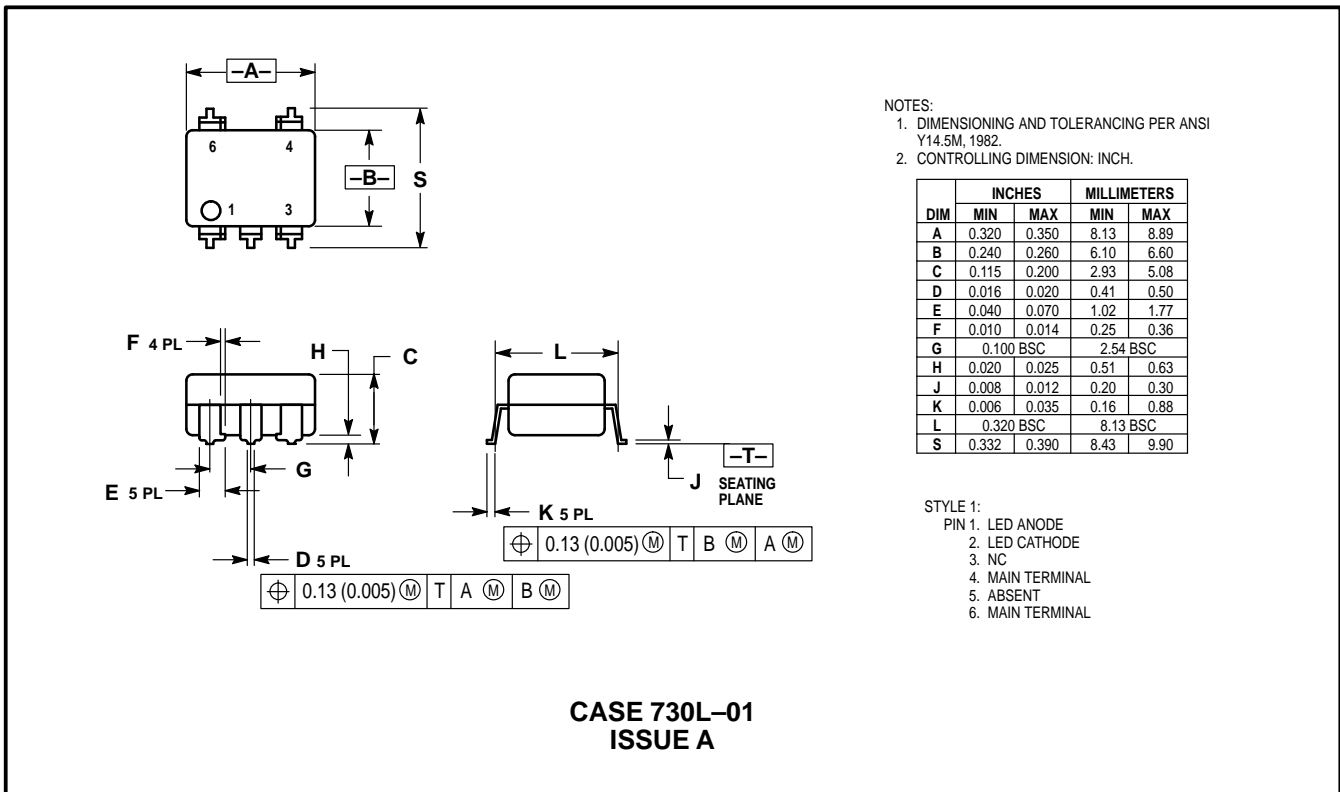
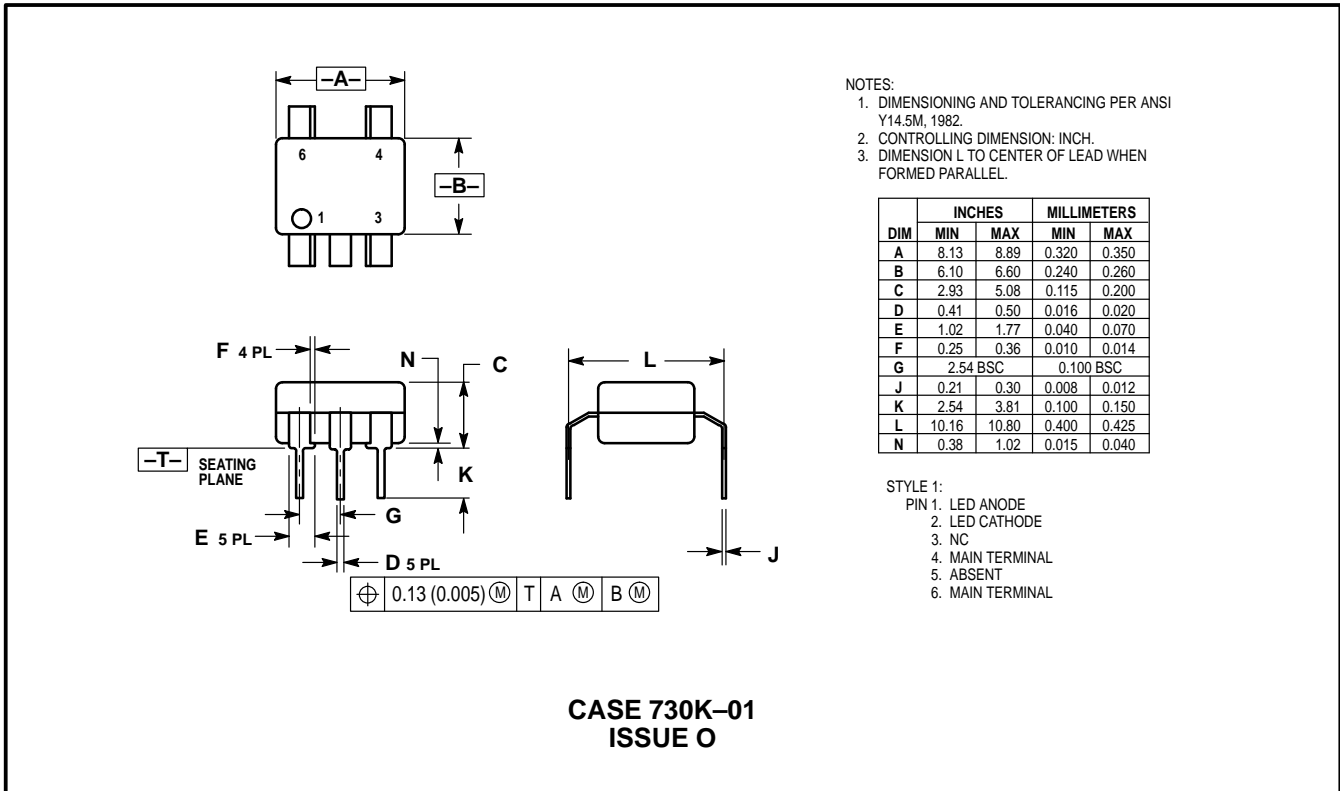

Motorola reserves the right to make changes without further notice to any products herein. Motorola makes no warranty, representation or guarantee regarding the suitability of its products for any particular purpose, nor does Motorola assume any liability arising out of the application or use of any product or circuit, and specifically disclaims any and all liability, including without limitation consequential or incidental damages. "Typical" parameters which may be provided in Motorola data sheets and/or specifications can and do vary in different applications and actual performance may vary over time. All operating parameters, including "Typicals" must be validated for each customer application by customer's technical experts. Motorola does not convey any license under its patent rights nor the rights of others. Motorola products are not designed, intended, or authorized for use as components in systems intended for surgical implant into the body, or other applications intended to support or sustain life, or for any other application in which the failure of the Motorola product could create a situation where personal injury or death may occur. Should Buyer purchase or use Motorola products for any such unintended or unauthorized application, Buyer shall indemnify and hold Motorola and its officers, employees, subsidiaries, affiliates, and distributors harmless against all claims, costs, damages, and expenses, and reasonable attorney fees arising out of, directly or indirectly, any claim of personal injury or death associated with such unintended or unauthorized use, even if such claim alleges that Motorola was negligent regarding the design or manufacture of the part. Motorola and  are registered trademarks of Motorola, Inc. Motorola, Inc. is an Equal Opportunity/Affirmative Action Employer.

Mfax is a trademark of Motorola, Inc.

How to reach us:

USA/EUROPE/Locations Not Listed: Motorola Literature Distribution;
P.O. Box 5405, Denver, Colorado 80217. 303-675-2140 or 1-800-441-2447

JAPAN: Nippon Motorola Ltd.; Tatsumi-SPD-JLDC, 6F Seibu-Butsuryu-Center,
3-14-2 Tatsumi Koto-Ku, Tokyo 135, Japan. 81-3-3521-8315

Mfax™: RMFAX0@email.sps.mot.com – TOUCHTONE 602-244-6609
– US & Canada ONLY 1-800-774-1848

ASIA/PACIFIC: Motorola Semiconductors H.K. Ltd.; 8B Tai Ping Industrial Park,
51 Ting Kok Road, Tai Po, N.T., Hong Kong. 852-26629298

INTERNET: <http://www.mot.com/SPS/>



MOTOROLA

